

SHARP®

MODEL
56DR650
65DR650

REAR PROJECTION TV
OPERATION MANUAL



Products that have earned the ENERGY STAR® are designed to protect the environment through superior energy efficiency.



DEAR SHARP CUSTOMER

Thank you for your purchase of this Sharp Rear Projection Television. To ensure safety and many years of trouble-free operation of your product, please read the Important Safety Instructions carefully before using this product.

IMPORTANT:

To aid reporting in case of loss or theft, please record the TV's model and serial numbers in the space provided. The numbers are located at the rear of the TV.

Model No.:

Serial No.:

IMPORTANT INFORMATION

WARNING: TO REDUCE THE RISK OF FIRE OR ELECTRIC SHOCK, DO NOT EXPOSE THIS PRODUCT TO RAIN OR MOISTURE.



CAUTION
RISK OF ELECTRIC SHOCK.
DO NOT REMOVE SCREWS
EXCEPT SPECIFIED USER
SERVICE SCREW.



**CAUTION: TO REDUCE THE RISK OF ELECTRIC SHOCK,
DO NOT REMOVE COVER .
NO USER-SERVICEABLE PARTS EXCEPT LAMP UNIT.
REFER SERVICING TO QUALIFIED SERVICE
PERSONNEL.**



The lightning flash with arrow-head symbol, within an equilateral triangle, is intended to alert the user to the presence of uninsulated "dangerous voltage" within the product's enclosure that may be of sufficient magnitude to constitute a risk of electric shock to persons.



The exclamation point within a triangle is intended to alert the user to the presence of important operating and maintenance (servicing) instructions in the literature accompanying the product.

WARNING:

The cooling fan in this REAR PROJECTION TV continues to run for about 150 seconds before the REAR PROJECTION TV enters the standby mode. During normal Operation, when putting the REAR PROJECTION TV into standby mode always use the POWER button on the REAR PROJECTION TV or on the remote control. Ensure the cooling fan has stopped before disconnecting the power cord. DURING NORMAL OPERATION, NEVER TURN THE TELEVISION OFF BY DISCONNECTING THE POWER CORD. FAILURE TO OBSERVE THIS COULD RESULT IN PREMATURE LAMP FAILURE.

WARNING :

EYE DAMAGE MAY RESULT FROM DIRECTLY VIEWING THE LIGHT PRODUCED BY THE LAMP USED IN THIS APPARATUS. ALWAYS TURN OFF LAMP BEFORE OPENING THIS COVER.

MISE EN GARDE :

VOUS RISQUEZ DES DOMMAGES OCULAIRES EN REGARDANT DIRECTEMENT LA LUMIÈRE PRODUITE PAR LA LAMPE UTILISÉE DANS CET APPAREIL. ÉTEIGNEZ TOUJOURS LA LAMPE AVANT D'OUVRIR SON CAPOT.



LAMP REPLACEMENT WARNING :

REFER TO THE INSTRUCTION MANUAL BEFORE REMOVING THE SCREW, DISCONNECT POWER CORD. HOT SURFACE INSIDE. ALLOW 45 MINUTES TO COOL BEFORE REPLACING THE LAMP. REPLACE WITH SAME LAMP UNIT ONLY.

THIS COVER IS PROVIDED WITH AN INTERLOCK TO REDUCE THE RISK OF EXCESSIVE ULTRAVIOLET RADIATION. DO NOT DEFEAT ITS PURPOSE OR ATTEMPT TO SERVICE WITHOUT REMOVING COVER COMPLETELY.

MEDIUM PRESSURE LAMP : RISK OF EXPLOSION. POTENTIAL HAZARD OF GLASS PARTICLES IF LAMP HAS RUPTURED. HANDLE WITH CARE.



MISE EN GARDE CONCERNANT LE REMPLACEMENT DE LA LAMPE :

VEUILLEZ VOUS REPORTER AU MANUEL D'INSTRUCTIONS AVANT DE DÉVISSER LA VIS. DÉBRANCHEZ LE CORDON D'ALIMENTATION. CONTIENT UNE SURFACE CHAUDE. LAISSEZ REFROIDIR 45 MINUTES AVANT DE REMPLACER LA LAMPE.

REMPLEZ EXCLUSIVEMENT AVEC LA MÊME LAMPE.

CE CAPOT EST MUNI D'UN VERROU POUR RÉDUIRE LES RISQUES DE RAYONNEMENT ULTRAVIOLET EXCESSIF. NE VOUS PRIVEZ PAS DE CETTE PROTECTION. NE TENTEZ PAS DE TRAVAILLER SUR LA LAMPE SANS ENLEVER COMPLÈTEMENT LE CAPOT.

LAMPE À PRESSION MOYENNE : RISQUE D'EXPLOSION. DANGER POTENTIEL DE PARTICULES DE VERRE EN CAS DE RUPTURE DE LA LAMPE. MANIPULEZ AVEC SOIN.



USER SERVICE SCREW.
VIS POUR ENTRETIEN PAR
L'UTILISATEUR.

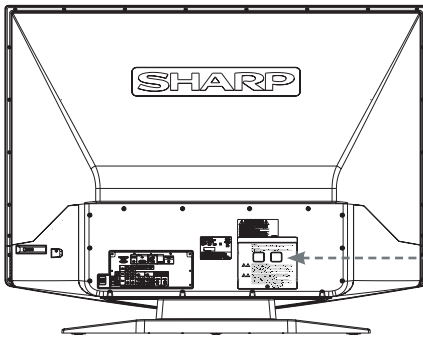

- Caution Concerning Lamp Replacement
See "Replacing the Lamp" on Page 33, 34

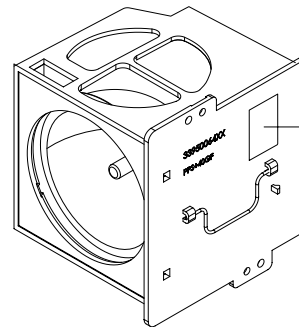

Potential hazard of glass particles if lamp ruptures. In case of lamp rupture, contact your nearest Sharp Authorized Projector Dealer or Service Center for a replacement. See "Replacing the Lamp" on Page 34

Replacement Lamp Part Numbers:

AN-R65LP1 (120W Lamp) 56DR650

AN-R65LP2 (135W Lamp) 65DR650

WARNING: FCC Regulations state that any unauthorized changes or modifications to this equipment not expressly approved by the manufacturer could void the users authority to operate this equipment.

CAUTION:

This product satisfies FCC regulations when shielded cables and connectors are used to connect the unit to other equipment. To prevent electromagnetic interference with electric appliances such as radios and televisions, use shielded cables and connectors for connections.

DECLARATION OF CONFORMITY

SHARP REAR PROJECTION TV, MODEL 56DR650

SHARP REAR PROJECTION TV, MODEL 65DR650

This device complies with Part 15 of the FCC Rules. Operation is subject to the following two conditions:

(1) This device may not cause harmful interference, and (2) this device must accept any interference received, including interference that may cause undesired operation.

RESPONSIBLE PARTY:

SHARP ELECTRONICS CORPORATION

Sharp Plaza, Mahwah, New Jersey 07430-2135

TEL: 1-800-BE-SHARP

For Business Customers: URL <http://www.sharppusa.com>

INFORMATION:

This equipment has been tested and found to comply with the limits for a Class B digital device, pursuant to Part 15 of the FCC Rules. These limits are designed to provide reasonable protection against harmful interference in a residential installation. This equipment generates, uses and can radiate radio frequency energy and, if not installed and used in accordance with the instructions, may cause harmful interference to radio communications. However, there is no guarantee that interference will not occur in a particular installation. If this equipment does cause harmful interference to radio or television reception, which can be determined by turning the equipment off and on, the user is encouraged to try to correct the interference by one or more of the following measures:

-Reorient or relocate the receiving antenna.

-Increase the separation between the equipment and receiver.

-Connect the equipment into an outlet on a circuit different from that to which the receiver is connected.

-Consult the dealer or an experienced radio/TV technician for help.

“Note to CATV system installer: This reminder is provided to call the CATV system installers attention to Article 820-40 of the National Electrical Code that provides guidelines for proper grounding and, in particular, specifies that the cable ground shall be connected to the grounding system of the building, as close to the point of cable entry as practical.”

This product utilizes tin-lead solder, and fluorescent lamp containing a small amount of mercury. Disposal of these materials may be regulated due to environmental considerations. For disposal or recycling information, please contact your local authorities or the Electronic Industries Alliance: www.eia.org

TRADEMARKS

• Manufactured under license from Dolby Laboratories. “Dolby” and the double-D symbol are trademarks of Dolby Laboratories.

• Manufactured under license from BBE Sound, Inc.
Licensed by BBE Sound, Inc. under USP, 5510752 and 5736897. BBE and BBE symbol are registered trademarks of BBE Sound, Inc.

• HDMI, the HDMI logo and High-Definition Multimedia Interface are trademarks or registered trademarks of HDMI Licensing LLC.

• DCDi[®] by Faroudja is a registered trademark of Genesis Microchip Inc.

• DLP[™] (Digital Light Processing) and DMD[™] (Digital Micromirror Device) are trademarks of Texas Instruments, Inc.
• Some IC chip in this product includes confidential and/or trade secret property belonging to Texas Instruments. Therefore you may not copy, translate, distribute, reverse engineer, reverse assemble or discompile the contents thereof.

IMPORTANT SAFETY INSTRUCTIONS

CAUTION:Please read all of these instructions before you operate this product and save these instruction for later use.

Electricity is used to perform many useful functions, but it can also cause personal injuries and property damage if improperly handled. This product has been engineered and manufactured with the highest priority on safety. However, improper use can result in electric shock and/or fire. In order to prevent potential danger, please observe the following instructions when installing, operating and cleaning the product. To ensure your safety and prolong the service life of your Rear Projection Television, please read the following precautions carefully before using the product.

- 1) Read these instructions.
- 2) Keep these instructions.
- 3) Heed all warnings.
- 4) Follow all instructions.
- 5) Do not use this apparatus near water.
- 6) Clean only with dry cloth.
- 7) Do not block any ventilation openings. Install in accordance with the manufacturer's instructions.
- 8) Do not install near any heat sources such as radiators, heat registers, stoves, or other apparatus (including amplifiers) that produce heat.
- 9) Do not defeat the safety purpose of the polarized or grounding-type plug. A polarized plug has two blades with one wider than the other. A grounding type plug has two blades and a third grounding prong. The wide blade or the third prong are provided for your safety. If the provided plug does not fit into your outlet, consult an electrician for replacement of the obsolete outlet.
- 10) Protect the power cord from being walked on or pinched particularly at plugs, convenience receptacles, and the point where they exit from the apparatus.
- 11) Only use attachments/accessories specified by the manufacturer.
- 12) Use only with the cart, stand, tripod, bracket, or table specified by the manufacturer, or sold with the apparatus. When a cart is used, use caution when moving the cart/apparatus combination to avoid injury from tip-over.
- 13) Unplug this apparatus during lightning storms or when unused for long periods of time.
- 14) Refer all servicing to qualified service personnel. Servicing is required when the apparatus has been damaged in any way, such as power-supply cord or plug is damaged, liquid has been spilled or objects have fallen into the apparatus, the apparatus has been exposed to rain or moisture, does not operate normally, or has been dropped. 
- 15) Power Sources — This product should be operated only from the type of power source indicated on the marking label. If you are not sure of the type of power supply to your home, consult your product dealer or local power company. For products intended to operate from battery power, or other sources, refer to the operating instructions.
- 16) Overloading — Do not overload wall outlets, extension cords, or integral convenience receptacles as this can result in a risk of fire or electric shock.
- 17) Object and Liquid Entry — Never push objects of any kind into this product through openings as they may touch dangerous voltage points or short-out parts that could result in a fire or electric shock. Never spill liquid of any kind on the product.
- 18) Damage Requiring Service — Unplug this product from the wall outlet and refer servicing to qualified service personnel under the following conditions:
 - a) When the AC cord or plug is damaged,
 - b) If liquid has been spilled, or objects have fallen into the product,
 - c) If the product has been exposed to rain or water,
 - d) If the product does not operate normally by following the operating instructions.
Adjust only those controls that are covered by the operating instructions as an improper adjustment of other controls may result in damage and will often require extensive work by a qualified technician to restore the product to its normal operation,
 - e) If the product has been dropped or damaged in any way, and
 - f) When the product exhibits a distinct change in performance – this indicates a need for service.
- 19) Replacement Parts — When replacement parts are required, be sure the service technician has used replacement parts specified by the manufacturer or have the same characteristics as the original part. Unauthorized substitutions may result in fire, electric shock, or other hazards.
- 20) Safety Check — Upon completion of any service or repairs to this product, ask the service technician to perform safety checks to determine that the product is in proper operating condition.

IMPORTANT SAFETY INSTRUCTIONS

• Water and Moisture — Do not use this product near water – for example, near a bath tub, wash bowl, kitchen sink, or laundry tub; in a wet basement; or near a swimming pool; and the like.

• Selecting the location — Select a place with no direct sunlight and good ventilation.

• Ventilation — The vents and other openings in the cabinet are designed for ventilation. Do not cover or block these vents and openings since insufficient ventilation can cause overheating and/or shorten the life of the product. Do not place the product on a bed, sofa, rug or other similar surface, since they can block ventilation openings. This product is not designed for built-in installation; do not place the product in an enclosed place such as a bookcase or rack, unless proper ventilation is provided or the manufacturer's instructions are followed.

• Heat — The product should be situated away from heat sources such as radiators, heat registers, stoves, or other products (including amplifiers) that produce heat.

• Lightning — For added protection for this television equipment during a lightning storm, or when it is left unattended and unused for long periods of time, unplug it from the wall outlet and disconnect the antenna. This will prevent damage to the equipment due to lightning and power-line surges.

• Power Lines — An outside antenna system should not be located in the vicinity of overhead power lines or other electric light or power circuits, or where it can fall into such power lines or circuits. When installing an outside antenna system, extreme care should be taken to keep from touching such power lines or circuits as contact with them might be fatal.

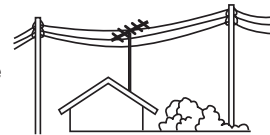

• Outdoor Antenna Grounding — If an outside antenna is connected to the television equipment, be sure the antenna system is grounded so as to provide some protection against voltage surges and built-up static charges. Article 810 of the National Electrical Code, ANSI/NFPA 70, provides information with regard to proper grounding of the mast and supporting structure, grounding of the lead-in wire to an antenna discharge unit, size of grounding conductors, location of antenna-discharge unit, connection to grounding electrodes, and requirements for the grounding electrode.

EXAMPLE OF ANTENNA GROUNDING AS PER NATIONAL ELECTRICAL CODE, ANSI/NFPA 70

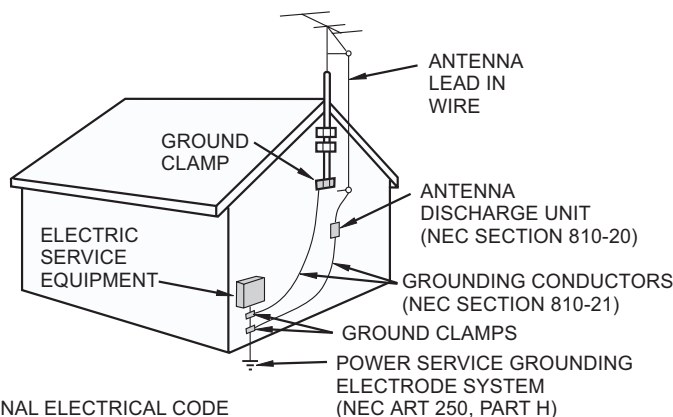

• To prevent fire or shock hazard, do not expose this product to dripping or splashing. No objects filled with liquids, such as vases, should be placed on the product.

• To prevent fire or shock hazard, do not place the AC power cord under the TV set or other heavy items.

Contents

DEAR SHARP CUSTOMER-----	ii	Français	
IMPORTANT INFORMATION-----	ii	CHER CLIENT SHARP -----	55
TRADEMARKS -----	iv	MARQUES-----	56
IMPORTANT SAFETY INSTRUCTIONS -----	v	IMPORTANTES INSTRUCTIONS DE SÉCURITÉ ---	57
Contents -----	1	Contrôles latéraux -----	59
Main Features-----	2	Voyant DEL d'état -----	60
Supplied Accessories -----	3	Fonctions des touches de la télécommande-----	61
Before Operating Your Rear Projection Television--	3		
Antenna Connections -----	5		
Using The Video and Audio Input Jacks-----	7		
Connecting your Digital Video Equipment (HDMI & DVI)	8		
-----	8		
Connecting your DVD Player -----	9		
Connecting your GAME CONSOLE or CAMCORDER	11		
-----	11		
Connecting Your Computer -----	12		
Computer Compatibility Chart-----	13		
Using the Center Channel Input -----	14		
Using the Audio Output -----	15		
Side Control Section-----	16		
Status LED -----	17		
Remote Control Key Functions-----	18		
Remote Control Operation-----	21		
Menu Functions -----	24		
Getting Started -----	24		
Using the On Screen Display (OSD) -----	25		
Setting a Password -----	29		
Television Antenna Connection Protection -----	30		
Using Wide Modes: View Mode-----	31		
Cleaning & Maintenance -----	32		
Replacing the Lamp-----	33		
Status LEDs -----	34		
Troubleshooting Guide -----	35		
Specifications -----	37		
Dimension -----	39		
Input / Output Terminals and Connectable Equipment	40		
-----	40		
Index -----	41		
APPENDIX: Remote Control IR Set Up Codes-----	43		
Español			
ESTIMADO CLIENTE DE SHARP -----	46		
INFORMACIÓN IMPORTANTE -----	46		
MARCAS COMERCIALES-----	47		
INSTRUCCIONES DE SEGURIDAD IMPORTANTES	48		
-----	48		
Sección de control lateral-----	50		
LED de estado -----	51		
Funciones de los botones del mando a distancia--	52		

Main Features

Please enjoy your Rear Projection Television (RPTV) that features:

- Texas Instruments® latest 0.55" DLP™ (Digital Light Processing) third generation HD3 Digital Micromirror Device (DMD) which features Smooth Picture™ technology for the very best image quality.
- Built in ATSC and NTSC tuners for enjoying digital and analog “ off air” broadcast signals.
- View high definition signals by using an external HDTV Set Top Box (Satellite or Cable) and RGB, HDMI, DVI or component video outputs from the STB into the RPTV.
- An HDMI terminal for Digital video equipment that supports HDCP (High-bandwidth Digital Content Protection).
- Two high-definition capable component video inputs that automatically synchronize with your RPTV to match the incoming source.
- Three sets of A/V inputs for conventional video equipment such as DVD players, VCRs etc.
- PC signal input: RGB D-SUB
- Supported signals:
 - 480i, 480p, 720p and 1080i
 - Automatically converts all signals to 720p display format.
 - HDMI Video Mode: 480p, 720p, 1080i.
 - HDMI PC Mode: VGA
 - Computer Input : 1024x768 XGA
- Bright, Flicker-free images with outstanding image detail and clarity.
- Film Mode 3:2 pull down for automatic detection and conversion of film based content for accurate display with minimal motion artifacts and video noise.
- High contrast ratio that delivers accurate color processing and deep black levels.
- Picture-in-Picture (PIP) modes that let you watch multiple programs or video sources simultaneously
- A Digital Zoom mode that eliminates “ back bars” around the display image.
- An integrated audio system featuring BBE™ sound processing for maximized sound quality.
- Center Channel Input terminal that is convenient for Home Theater set up.
- Light up Universal Remote control

Other benefits include:

- No possible convergence errors.
- No screen aging, image retention or burn in effects.
- User-friendly replaceable lamp for hours of enjoyment.

Supplied Accessories

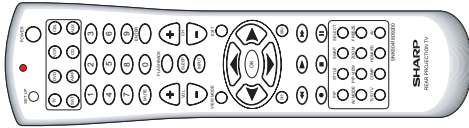
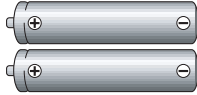
	
Infrared Remote Control Part Number : 9NK5041809200	Size AA Dry Batteries (2 pcs.)

Before Operating Your Rear Projection Television

Location

- For normal operation, your RPTV should be set up in the room where cool, adequate ventilation is provided. Do not position the back of the RPTV in a place where free airflow is restricted.
- Any magnetic force may disturb the color picture. Make sure that magnets, speakers, electric clocks, toys using magnets or any other magnetic equipment, such as an iron are kept well away from this RPTV.

Power

Your RPTV operates on 120 Volts, 60 Hertz (normal household current in the USA) and has a polarized plug. If you are unable to insert the plug fully into the outlet, try reversing the plug. If it does not fit, contact an electrician. Do not defeat the safety feature of the polarized plug.

- If the RPTV is not used for a long period, unplug the RPTV from the wall outlet to economize power. (If the RPTV is plugged in, slight current still flows, even with the POWER button in the OFF position.)
- When a FM tuner or radio is located near the RPTV Lines and other noise may appear in TV broadcast images when radio and TV broadcasts are received at the same time. If video noise more appears, turn off either the RPTV or the radio.
- If you are listening to AM broadcasts, turn the RPTV off. Some AM broadcast signals may not be received due to interference from the RPTV.

Viewing

Your TV is best viewed by sitting directly in front of it about 10 to 18 feet from the screen. The brightness decreases as the viewer moves to the left or to the right of the set.

During the daytime, reflections from light outside may appear on the screen. Drapes or screens can be used to reduce the reflection or the RPTV can be placed in a different location of the room.

If the RPTV's audio output is connected to a Hi-Fi system's external speakers, the best audio performance will be obtained by placing the speakers on each side of the set at an equal distance as well as on a height which is equal to that of the screen center. For best stereo separation, first place the external speakers at least four feet from each side of the RPTV, then place the surround speakers to the side or behind the viewing area. Due to the differences in room sizes and acoustic environments some experimentation regarding speaker placement for best performance will be required.

Remote Control

To use the remote control, insert batteries first.

1. Open the battery cover.
Pull up the lid in the direction of the arrow.

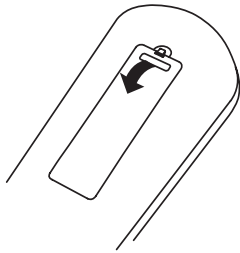

2. Load the batteries. Insert two "AA" size batteries supplied so that the battery poles are positioned as indicated.

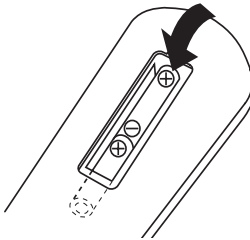

3. Close the battery cover.
Lower the lid in the direction of the arrow.

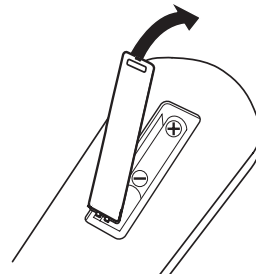

Antenna Connections

- To fully utilize the various features provided, such as the 2-Tuners Picture In Picture System, UNIVERSAL PLUS, and some connectors for high-quality VCR/DVD playback, set up this unit properly by following the procedures below.

Remote Control

- The Remote Control is compatible with various VCR/DVD players and other manufacture's A/V equipment by setting the correct control code. (Page 43)

Antennas

- The antenna required for good color RPTV reception are more important than those for black & white television reception. For this reason, a good quality outdoor antenna is strongly recommended.

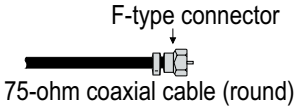
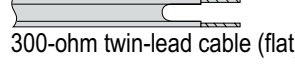
Type of connector	
<p>1. The 75 ohm system generally uses a round cable with an F-type connector that can easily be attached to a terminal without tools (not supplied) The F-type connector should be finger tightened only.</p>	 <p>F-type connector 75-ohm coaxial cable (round)</p>
<p>2. The 300 ohm system uses a flat "twin-lead" cable that can be attached to a 75 ohm terminal through a 300-75 ohm ADAPTOR (not supplied)</p>	 <p>300-ohm twin-lead cable (flat)</p>

- A good color picture depends on a strong TV signal. Ask your dealer for advice on how to install your external antenna to receive the best possible signal.
- If you subscribe to Cable or Satellite TV or have a central antenna in your building, you may not need an external antenna.

Antenna Connections

E. Connection with Antenna Cable

1. Cable without a CATV Converter
2. VHF/UHF Combination Antenna

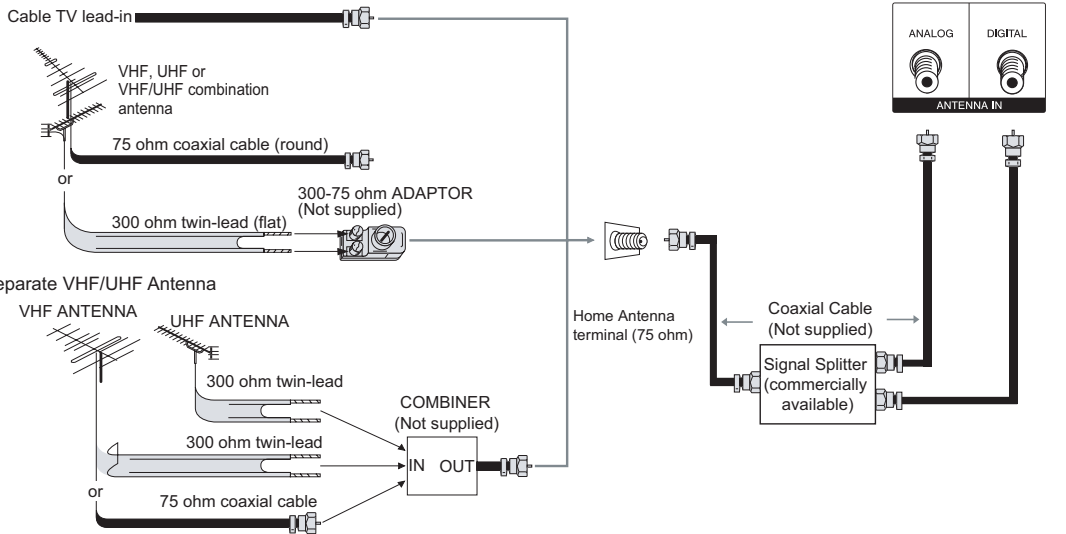

NOTICE:

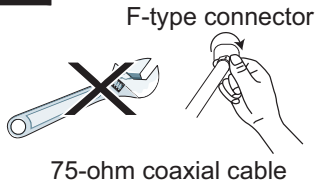

F-type connector should be finger-tightened only.

When connecting the RF cable to the TV set, do not tighten F-type connector with tools. If tools are used, it may cause damage to your TV set. (The breaking of internal circuit, etc.)

CABLE TV (CATV) CONNECTION

- A 75 ohm coaxial cable connector is built into the set for easy hookup. When connecting the 75 ohm coaxial cable to the set, screw the 75 ohm cable to the COAXIAL CABLE CONNECTOR.
- Some cable TV companies offer “premium pay channels”. Since the signals of these premium pay channels are scrambled, a cable TV converter/descrambler is generally provided to the subscriber by the cable TV company. This converter/descrambler is necessary for normal viewing of the scrambled channels. (Set your TV on channel 3 or 4. Typically one of these channels is used. If channel is unknown, consult your cable TV company.) For more specific instructions on installing cable TV, consult your cable TV company. One possible method of utilizing the converter/descrambler provided by your cable TV company is explained below.

Please note: RF switch equipped with position A/B (not provided) is required.

“A” position on the RF switch (not supplied) : You can view all unscrambled channels using the TV’s channel keys.

“B” position on the RF switch (not supplied) : You can view the scrambled channels via the converter/descrambler using the converter’s channel keys.

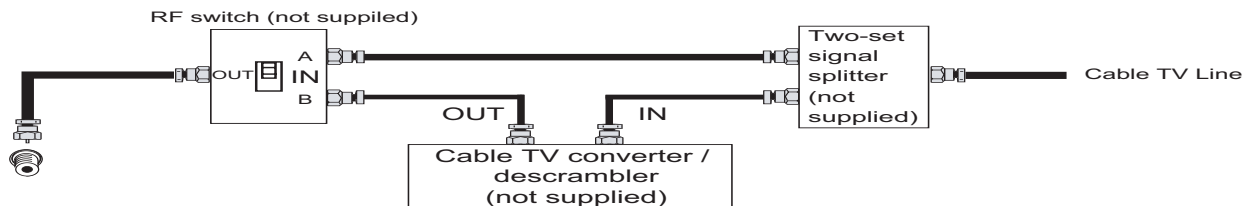

Note:

•Consult your SHARP Dealer or Service Center for the type of splitter, RF switch or combiner that might be required.

Using The Video and Audio Input Terminals

Using the Video and Audio Input Terminals

- Connecting video equipment for video playback.
- When the television is connected to video equipment as shown below, the material being played back on the video equipment can be seen on the television screen.

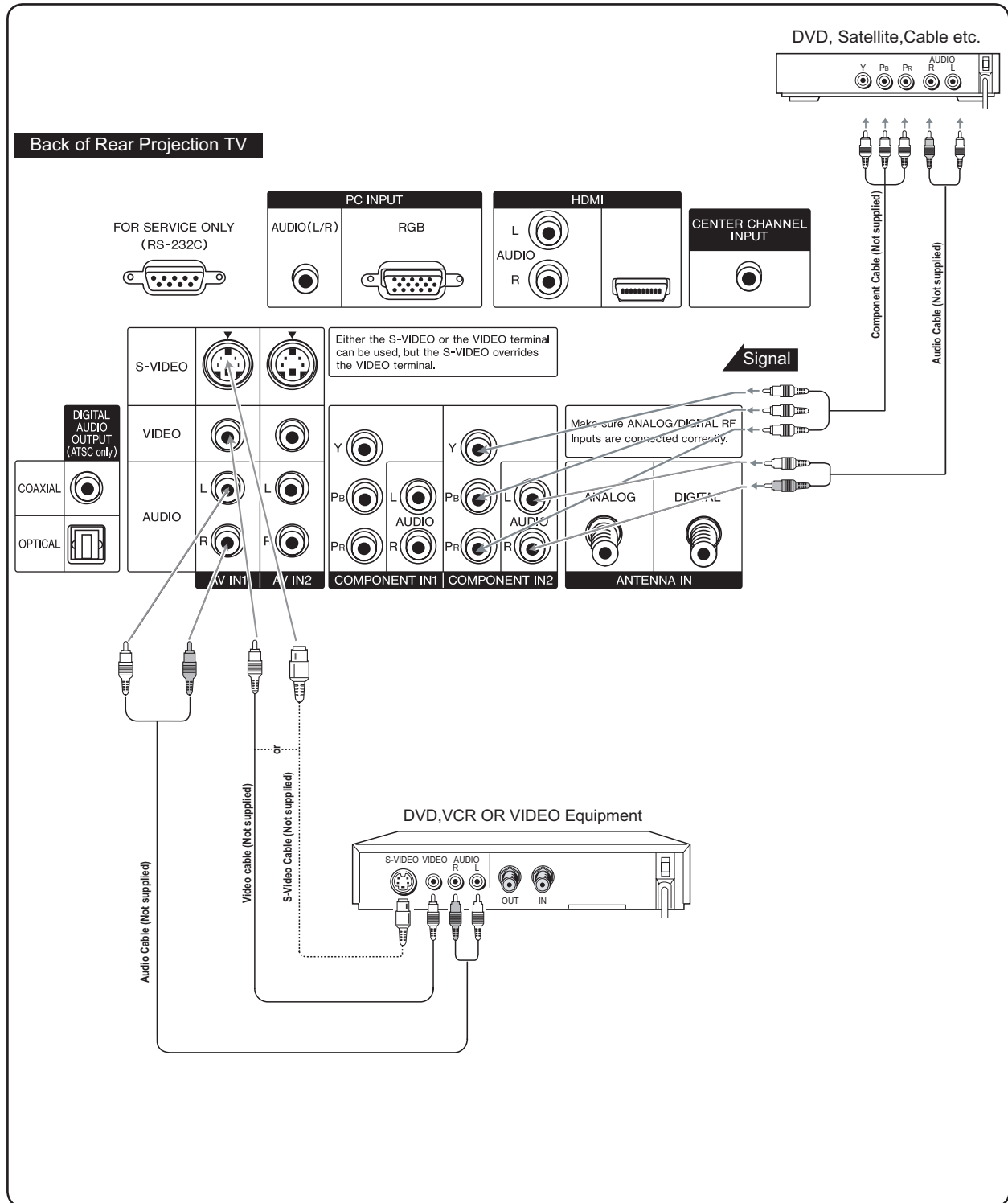

Connecting your Digital Video Equipment (HDMI & DVI)

Using Digital Video

Digital video equipment and other devices that have a digital interface compliant with the HDMI & DVI (Digital Visual Interface) standard should be connected to the HDMI input of the RPTV.

Note:

1. Turn off the power of the RPTV and digital video equipment.
2. Connect a HDMI cable to the output terminal of your digital video equipment and the other end to the HDMI input in the rear of your RPTV.
3. Turn on the power to the RPTV and your digital video equipment.
4. Select HDMI using the INPUT button on the right side of the RPTV or the remote control.
5. If your digital video equipment provides DVI output only, you should connect the DVI output from your Digital video equipment to the HDMI input on the rear of your RPTV. Connect both audio cables.
6. When using the DVI cable to reset OSD menu for "HDMI AUDIO" see page 27.
7. If your digital video equipment provides HDMI output, you should connect the cable from your digital video equipment to the HDMI input on the rear of your RPTV.

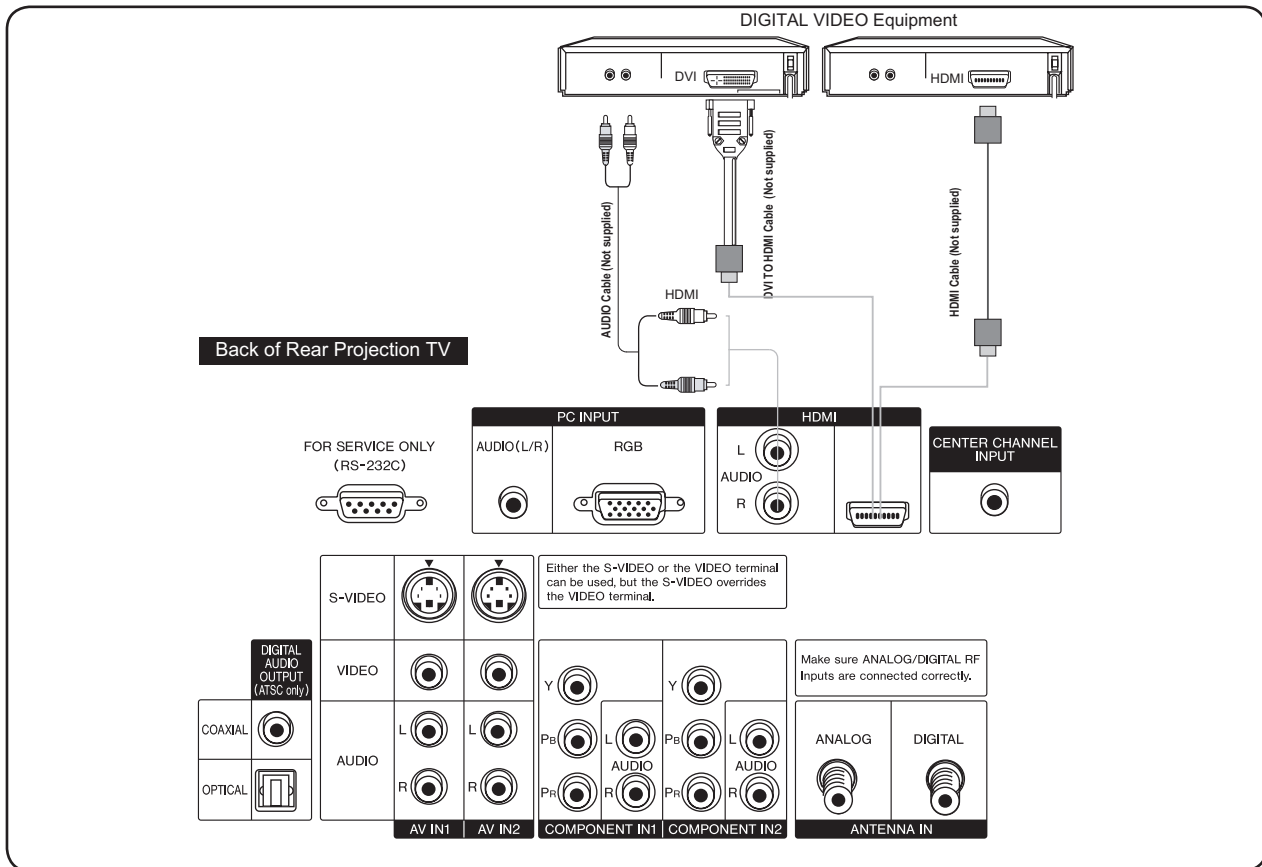

Note:

- a). The High Definition Multimedia Interface (HDMI). This interface is used between any audio/video source, such as a set-top box, DVD player, or A/V receiver, and an audio or video monitor, such as a DTV. HDMI supports standard, enhanced or high-definition video, plus multi-channel digital audio on a single cable. The format transmits all ATSC HDTV standards and supports eight-channel digital audio (up to 192kHz sampling rate), with bandwidth to spare for future enhancements.

HDMI also uses a more compact and consumer electronics-friendly 15mm, 19-pin connector and will be fully compatible with the former DVI-HDCP standard.

The HDMI input on your RPTV supports High-bandwidth Digital Content Protection (HDCP). HDMI encrypts the transmission between the video source and the digital display for added security and protection.

- b). Refer to your Digital Device's User Manual for more information about the video output requirements of the product.

Connecting your DVD Player

Using S-Video or Composite video

1. Turn off the power of the RPTV and DVD player.
2. Connect the S-Video or video (yellow color) terminal from the rear of your DVD player to the S-Video or video (yellow color) terminal in the AV IN on the rear of your RPTV.
3. Connect the R (red color) and L (white color) audio connectors from the rear of your DVD player to the R (red color) and L (white color) audio input connectors in the AV IN 2 on the rear of your RPTV.
4. Turn on the power of the RPTV and DVD player.
5. Select AV 2 using the INPUT button on the right side of the RPTV or on the remote control.

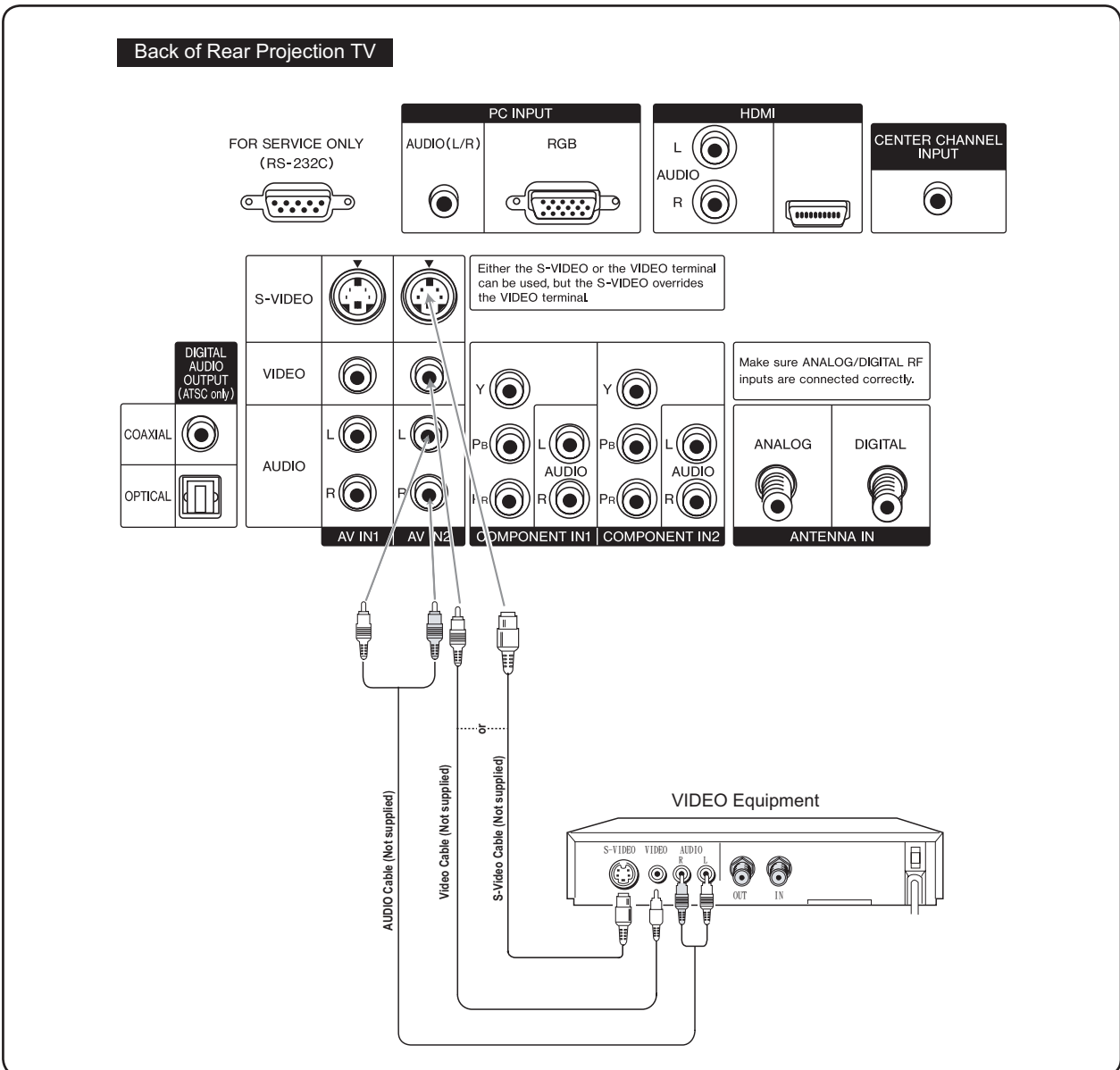

Note:

- a). If you are already using the AV IN 2 input for another component, or you do not want to use the AV IN 2 input for the DVD player, you can connect the DVD player to the AV IN 1 group of connections.
- b). Refer to your DVD player User Manual for more information about the video output requirements of the product.

Connecting your DVD Player

Using Component Video

1. Turn off the power to the RPTV and DVD player.
2. Connect the PR or CR (red color) connector from the rear of your DVD player to the PR/CR (red color) connector in the COMPONENT IN 1 on the rear of your RPTV.
3. Connect the PB or CB (blue color) connector from the rear of your DVD player to the PB/CB (blue color) connector in the COMPONENT IN 1 on the rear of your RPTV.
4. Connect the Y (green color) connector from the rear of your DVD player to the Y (green color) connector in the COMPONENT IN 1 on the rear of your RPTV.
5. Connect the R (red color) and L (white color) audio connectors from the rear of your DVD player to the R (red color) and L (white color) audio input connectors in the COMPONENT IN 1 from the rear of your RPTV.
6. Turn on the power of the RPTV and DVD player.
7. Select COMP 1 using the INPUT button on the right side of the RPTV or on the remote control.

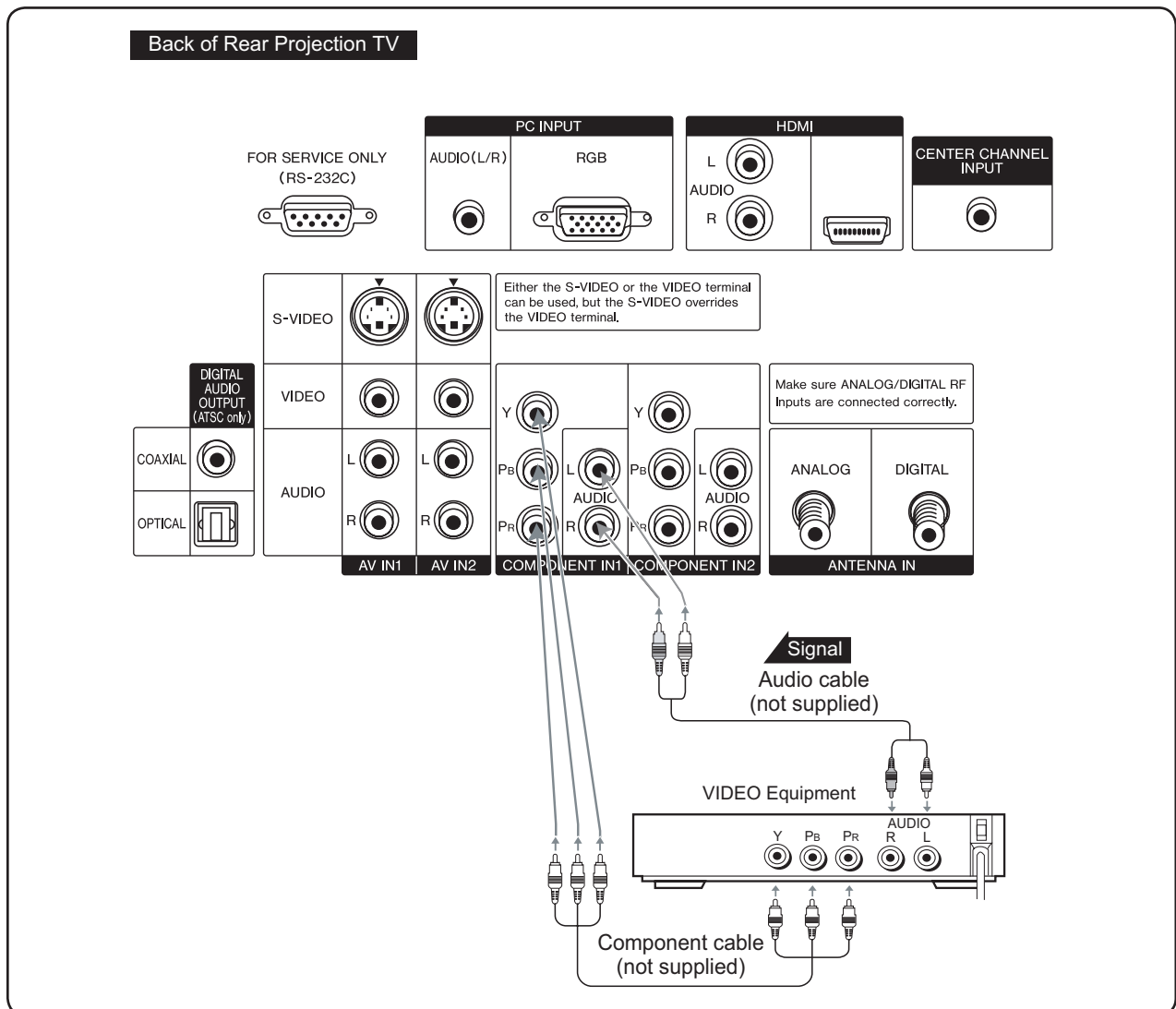

Note:

- a). If you are already using the Component IN1 input for another component, or you do not want to use the Component IN1 input for the DVD player, you can connect the DVD player to the Component IN2 group of connections.
- b). Refer to your DVD player User Manual for more information about the video output requirements of the product.

Connecting your GAME CONSOLE or CAMCORDER

Using S-Video

1. Turn off the power of the RPTV and GAME CONSOLE or CAMCORDER.
2. Connect the S-Video terminal from your GAME CONSOLE or CAMCORDER to the S-Video terminal in AV IN 3 on the right side of your RPTV.
3. Connect the R (red color) and L (white color) audio connectors from your GAME CONSOLE or CAMCORDER to the R (red color) and L (white color) audio input connectors in AV IN 3 on the right side of your RPTV.
4. Turn on the power to the RPTV and GAME CONSOLE or CAMCORDER.
5. Select AV IN 3 using the INPUT button on the right side of the RPTV or on the remote control.

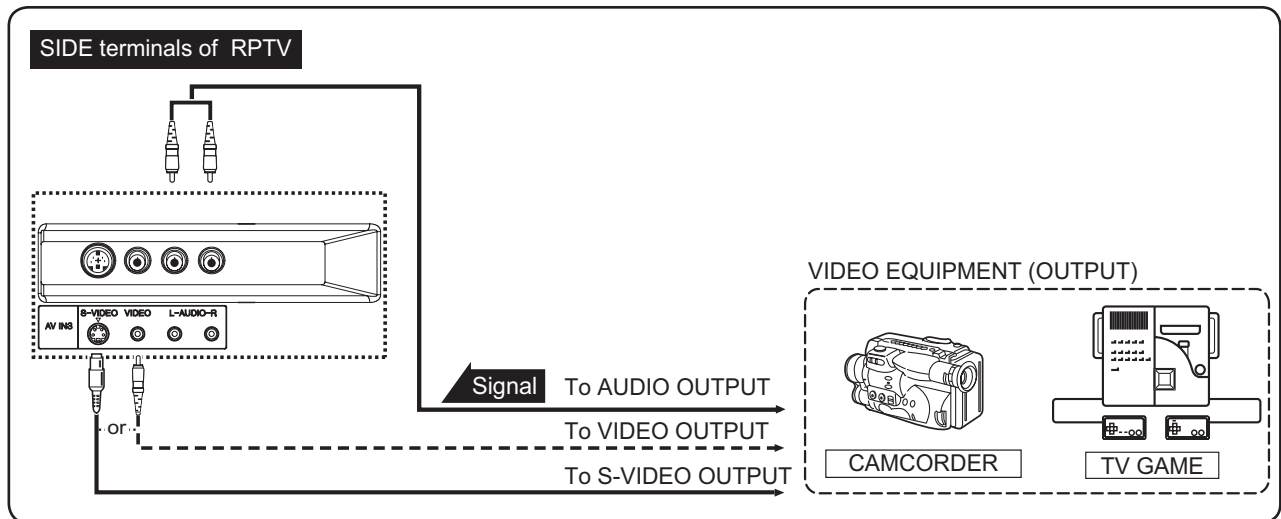

Note:

- The S-VIDEO INPUT terminal offers a higher quality image by accepting the signal separated into color and brightness signals.
- The S-VIDEO INPUT terminal are for video signal only. The audio signals are connected to AV IN3.

Connecting Your Computer

Using PC INPUT

1. Turn off the power of the RPTV and Computer.
2. Connect a VGA cable from the VGA CARD of your computer to the PC input in the rear of your RPTV.
3. Connect the Audio Out mini-jack from your computer to the VGA Audio (L/R) from the rear of your RPTV.
4. Turn on the power of the RPTV and your computer.
5. Select RGB using the INPUT button on the right side of the RPTV or on the remote control.

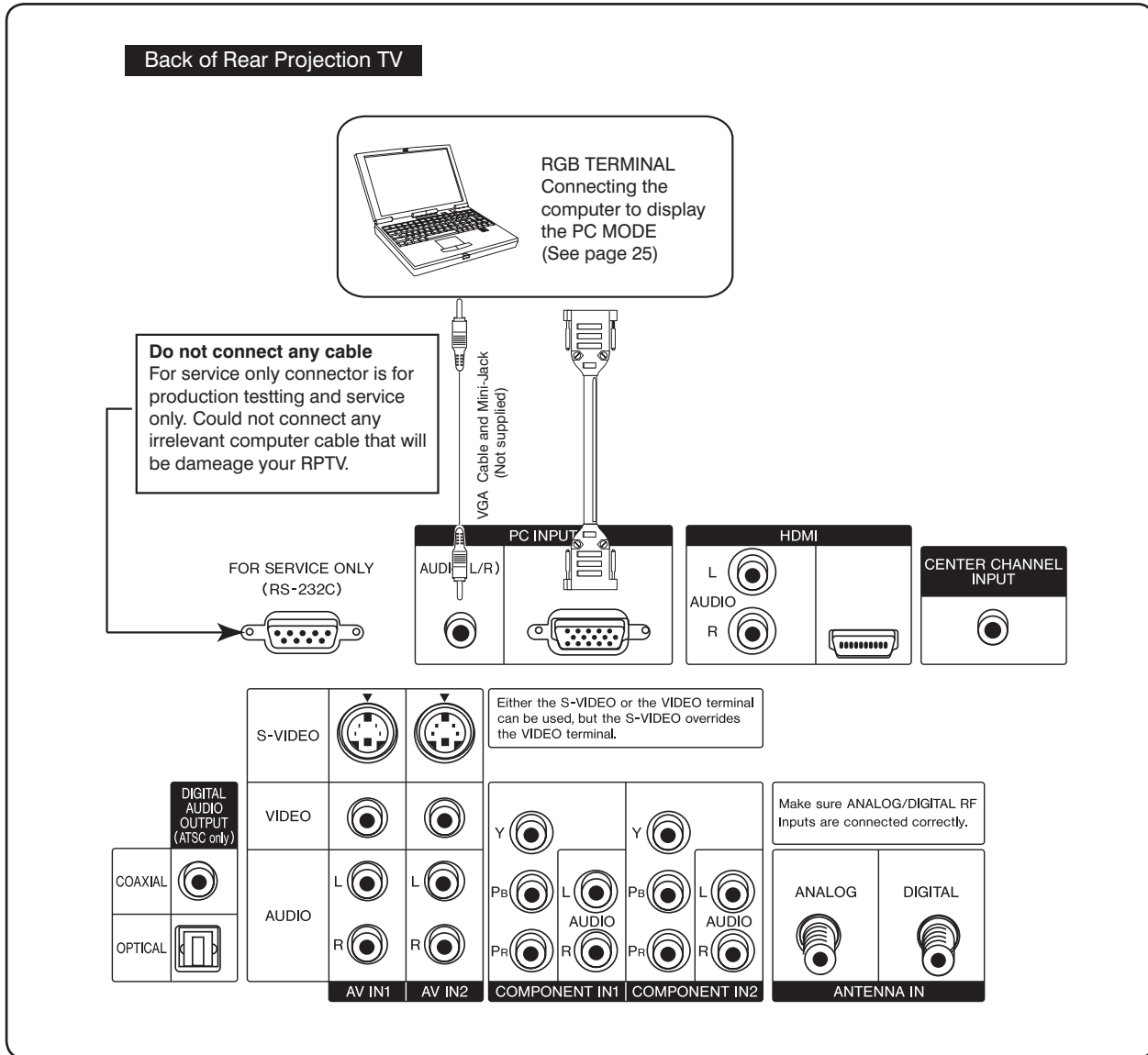

Note:

- a. The PC input on your RPTV supports High-bandwidth Digital Content Protection (HDCP). HDCP encrypts the transmission between the video source and the digital display for added security and protection.
- b. Refer to your computer User Manual for more information about the video output requirements of the product.

Computer Compatibility Chart

Computer

- | | |
|--|--|
| <ul style="list-style-type: none"> • Multiple signal support Horizontal Frequency: 15-60 kHz, Vertical Frequency: 45-85 Hz, Pixel Clock: 12-80 MHz Sync signal: Compatible with TTL level | <ul style="list-style-type: none"> • Compatible with sync on green signal • XGA compatible in intelligent compression • Intelligent Compression and Expansion System re sizing technology |
|--|--|

Input mode	Signal Format		STRETCH	NORMAL	ZOOM	DOT BY DOT	Factory Preset	
RGB	640*400	70Hz	O	O	O	O	NORMAL	
		85Hz	O	O	O	O		
	720*400	70Hz	O	O	O	O	NORMAL	
		85Hz	O	O	O	O		
	720*480	60Hz	O	O	O	O	NORMAL	
		60Hz	O	O	O	O		
	640*480		72Hz	O	O	O	O	NORMAL
			75Hz	O	O	O	O	
			85Hz	O	O	O	O	
			85Hz	O	O	O	O	
	800*600		56Hz	O	O	O	O	NORMAL
			60Hz	O	O	O	O	
			70Hz	O	O	O	O	
			72Hz	O	O	O	O	
			75Hz	O	O	O	O	
1024*768		85Hz	O	O	O	O	NORMAL	
		60Hz	O	O	O	O		
		70Hz	O	O	O	O		
1280*720		75Hz	O	O	O	O	-	
		60Hz	X	X	X	O		
HDMI	640*480	60Hz	O	O	O	O	SIDE BAR	
No Signal			O	X	X	X	-	

O : Possible

X : Not Possible

Note :

- This RPTV may not be able to display images from notebook computers in simultaneous (CRT/LCD) mode. Should this occur, turn off the LCD display on the notebook computer and output the display data in "CRT only" mode. Details on how to change display modes can be found in your notebook computer's operation manual.
- When signal not supported inputs, the screen will show "UNAVAILABLE" words ; But when the signal supported inputs and shows picture oblique , need to use "AUTOSYNC" function, if "AUTOSYNC" function picture still have oblique, must choose "H-POS/V-POS" to adjust it.

Using the Center Channel Input

You can use the RPTV speakers as a center speaker when using 5.1ch surround sound system.

1. Turn off the power of the RPTV and audio equipment which supports 5.1ch surround sound system.
2. Connect the center speaker connector from the rear of your audio equipment to the CENTER CHANNEL INPUT on the rear of your RPTV.
3. Turn on the power of the RPTV and audio equipment.
4. Press MENU button on the remote control and the "MAIN MENU" will be displayed on the screen.
5. Press the ▲ or ▼ button to select "SETUP".
6. Press the OK button and the main menu will change to the "SETUP".
7. Press the ▲ or ▼ button to select "SPEAKER".
8. Press the OK button.
9. Press the ◀ or ▶ button to select "CENTER-IN".

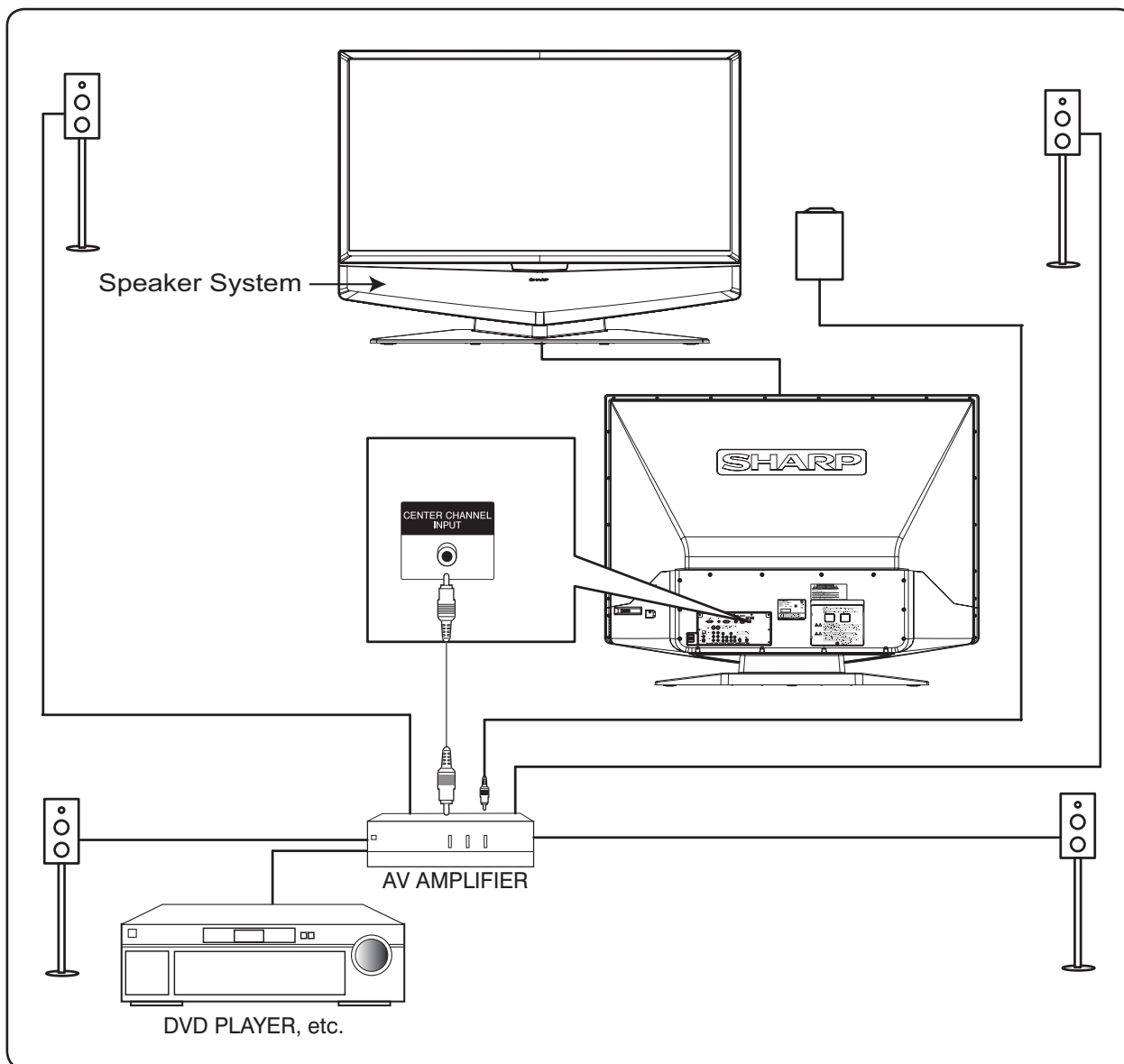

Note:

Refer to your audio equipment operation manual for details.

Using the Audio Output

These terminals are used for connecting a stereo amplifier for Digital TV Audio Signals only. They relay (pass-through) the audio signals of all DTV programs displayed on the RPTV screen.

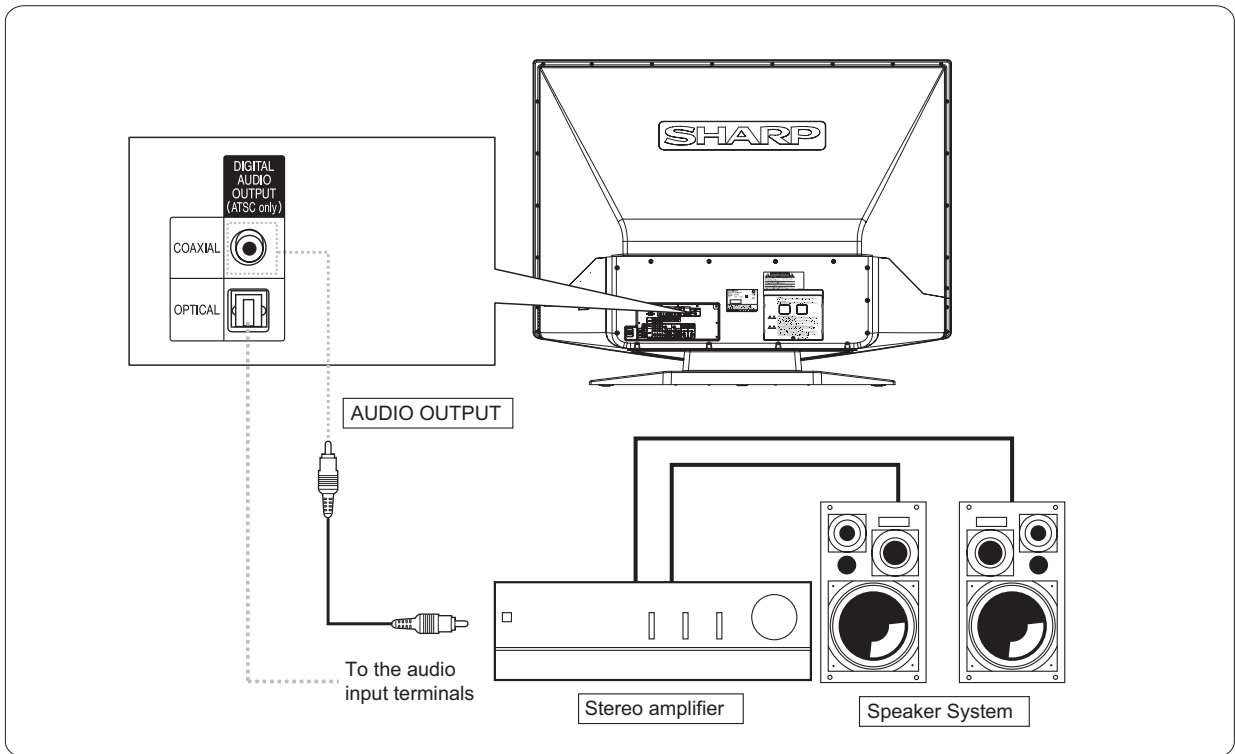

The Digital Audio output terminal is available for ATSC audio signals which are connected to the RF antenna.

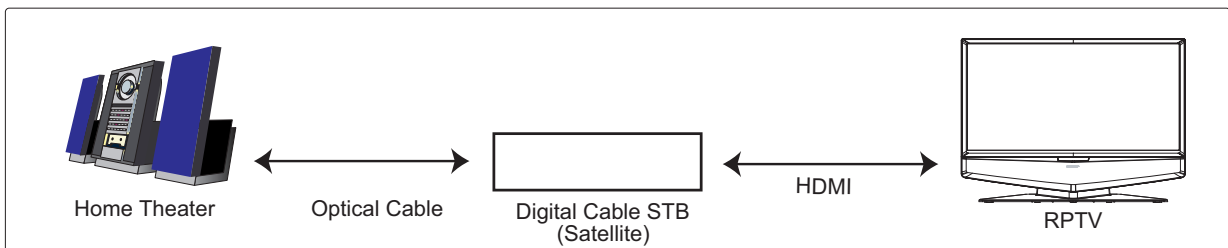

1. Turn off the RPTV and connect the audio cord or optical terminal to the DIGITAL AUDIO OUTPUT or OPTICAL terminal on the rear of television.
2. Adjust the amplifier volume for a moderate listening level and turn the RPTV and stereo amplifier on.
3. Adjust the VOLUME control on the stereo amplifier as desired.
4. To check SPEAKER connections, see page 40.

Note:

- For detailed information on the connection and use of auxiliary equipment, refer to the operation manuals of the equipment being used.
- When using VAO terminals, for optimal sound quality, it is recommended to keep the RPTV's audio output level high.

Side Control Section

POWER

Switch the TV “on” by pressing the POWER button once. To turn “off” the TV press the POWER button twice; the first time the button is pressed a message will appear on the screen warning that the second button press will power-off the TV.

INPUT

Repeated pressing of this button steps through the input sources in a circulatory sequence. Once you have selected all of the inputs you will return to the input you started at.

MENU & EXIT

Pressing this button activates the On Screen Display (OSD) and shows the Main Menu. Pressing this button again exits (closes) the OSD.

OK

Pressing this button activates the OSD and shows the Main Menu.

CHANNEL +/- & ADJUST ▲/▼

Step up (+) or down (-) through TV channels. While the OSD is active, these function as adjustment buttons to select OSD options.

VOLUME +/- & ADJUST ◀/▶

Increase (+) or decrease (-) the speaker volume. While the OSD is active, these function as adjustment buttons to adjust the OSD options.

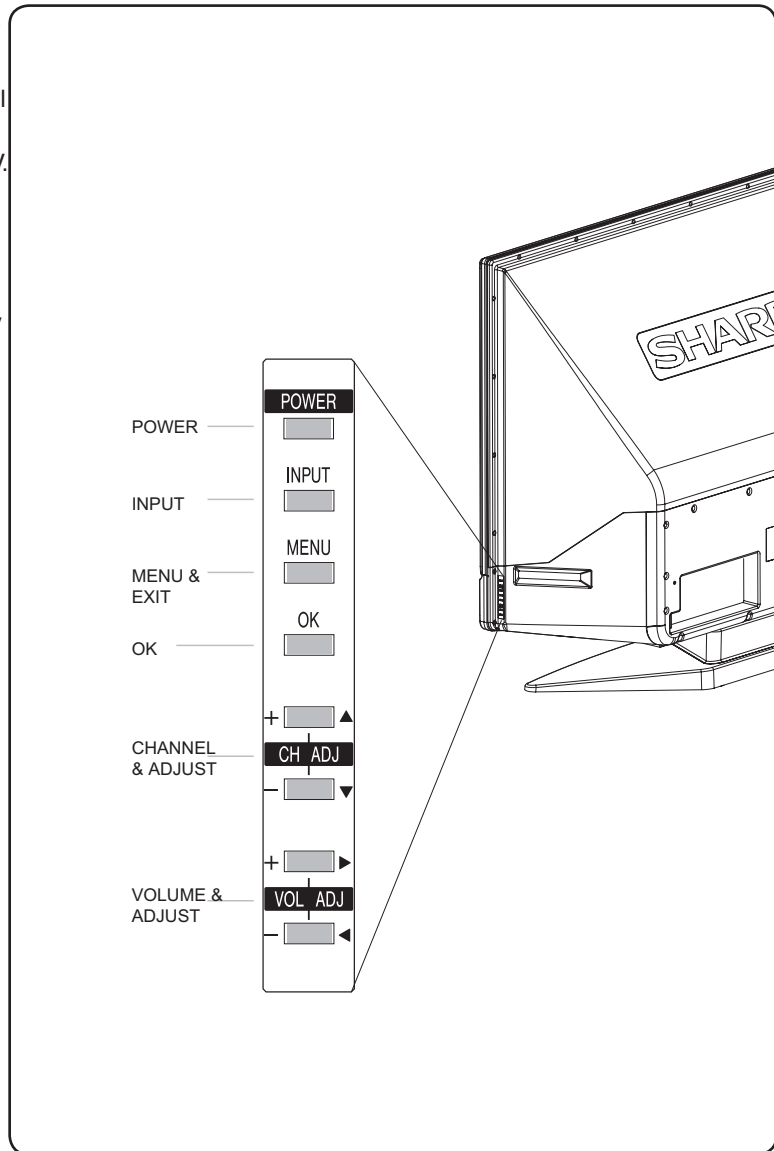

Status LED

Front Panel Indicator

LAMP LED

Displays the status of the lamp of your RPTV.

POWER LED

Lights green when powered on.

Remote Control Sensor

Point the Remote Control here as this is the window through which all of the remote signals pass to reach the remote sensor.

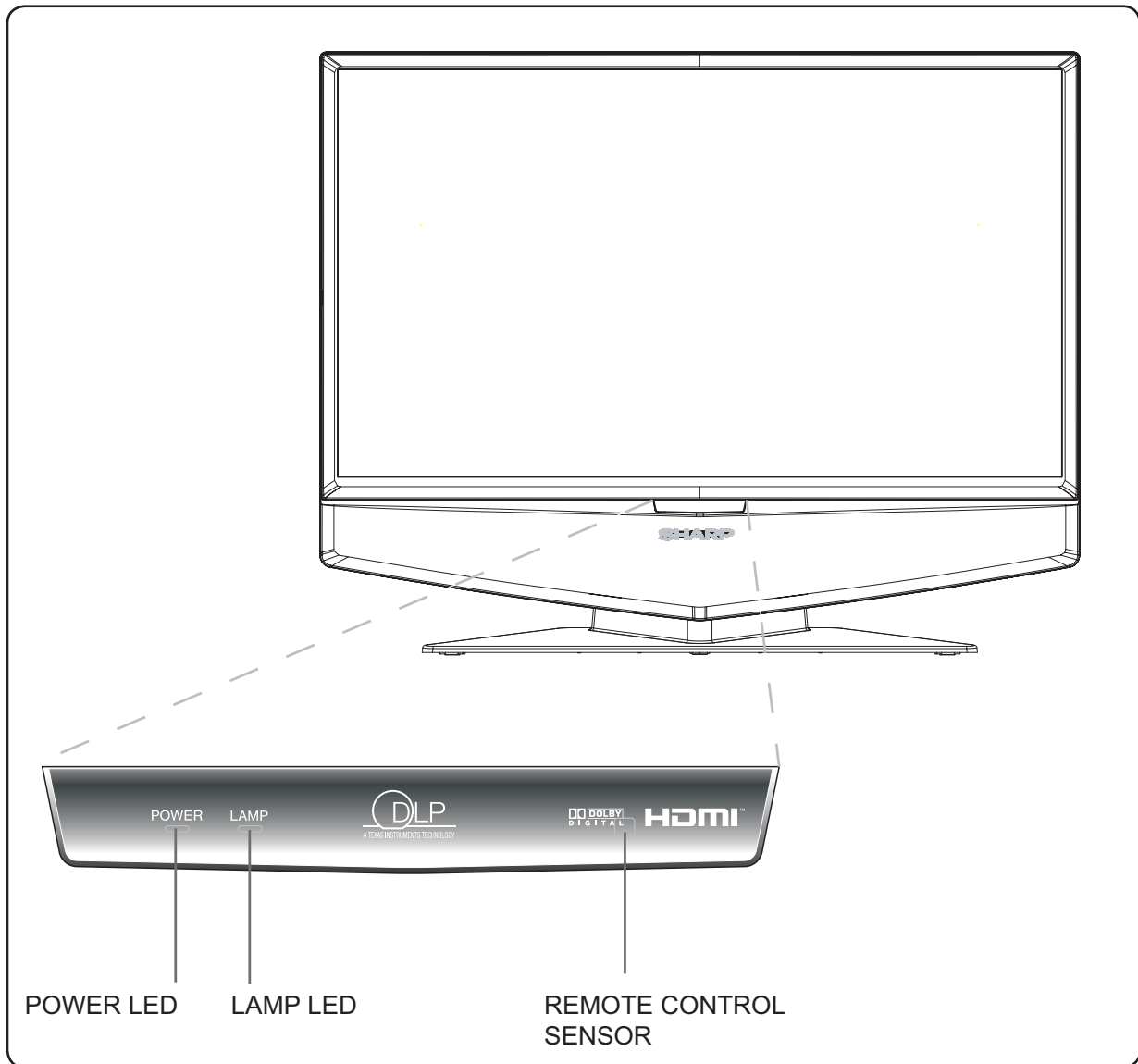

Remote Control Key Functions

The Remote Control is a comprehensive remote that can be used to control up to eight different components. For ease of use with minimal room lighting the Remote Control has a back light that illuminates all of the buttons when any button is pressed. The light will automatically go off a few seconds after the last button is pressed. The Remote Control button functions are explained below.

Remote LED

Blinks when the Remote Control is being programmed or sending a command to your RPTV.

SETUP

Starts all programming sequences.

POWER

Turns "on" or "off" your RPTV or other selected components.

Component buttons: You can program these buttons to select the components you wish the Remote Control to operate.

- TV is pre-programmed to operate your RPTV.
- DVD selects a programmed DVD Player.
- VCR selects a programmed VCR.
- CBL selects a cable set-top box.
- SAT selects a programmed satellite receiver.
- AMP selects a programmed receiver.
- CD selects a programmed CD Player.
- AUX selects a programmed component.

Number Pad

Use these buttons to select a TV channel directly by the channel number or enter the password.

Examples:

For channel 20 press the '2' button and then the '0' button within 5 seconds.

For channel 7 press the '7' button and wait about five (5) seconds;

ENTER ". " Sub channel select (ie. 2.1, 4.2 etc.)

FLASHBACK : Return to previous channel

MUTE : Volume off

SLEEP : Display the sleep time status

INPUT : Select the signal type DTV, AV1, AV2, AV3, COMP1, COMP2, RGB, HDMI, TV

VOL : Volume control press button "+" or "-"

CH : Channel select press button "+" or "-"

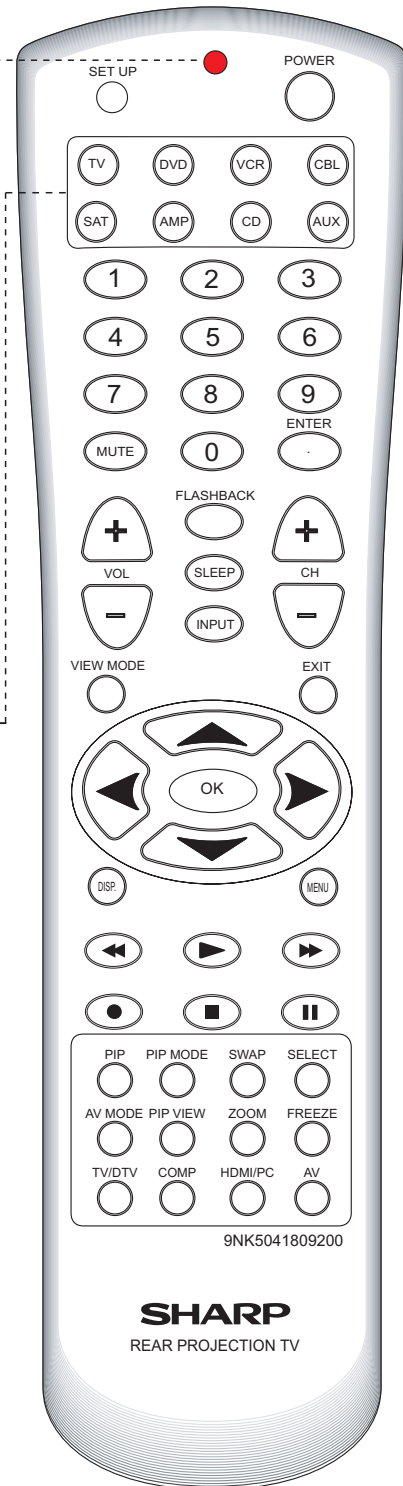

Remote Control Key Functions

VIEW MODE (WITH VIDEO)

- STRETCH 16:9
- SIDE BAR 4:3
- S.STRETCH
- ZOOM

VIEW MODE (WITH PC)

- NORMAL
- STRETCH 16:9
- DOT BY DOT
- ZOOM

EXIT

Exit the OSD, component or menus.

▲, ▼, ◀, ▶

Use these buttons to navigate the OSD menus.

OK

Confirm an action.

DISP.

Display the current status of the video source, audio (and channel number when in TV mode), on the screen of your RPTV.

MENU

Activates the OSD Menu and Exit the OSD direct.

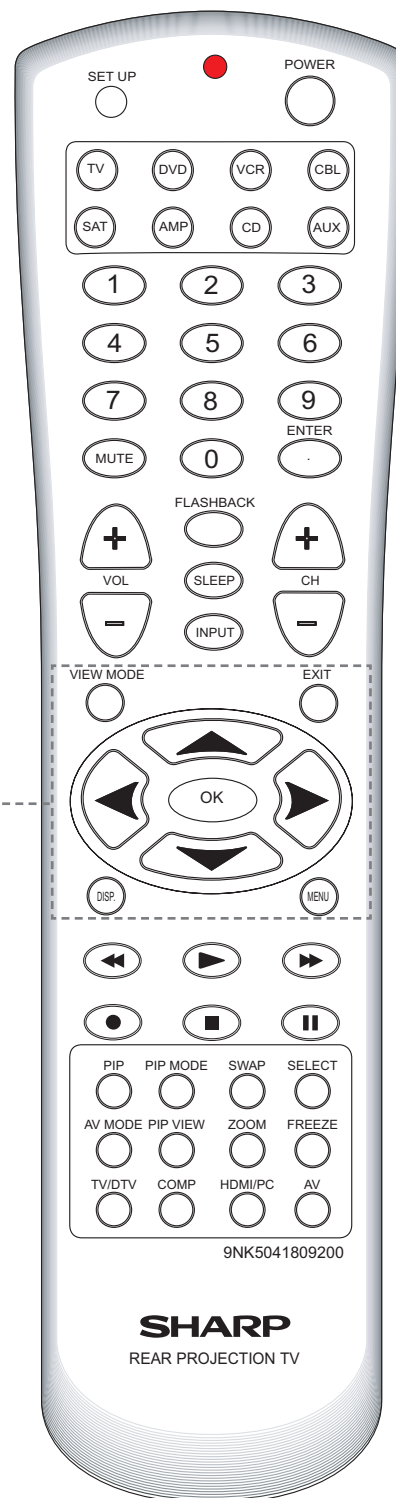

Remote Control Key Functions

PIP

Turn on or off the PIP (Picture In Picture) or POP (Picture On Picture) mode.

SELECT

Select the main or sub window to activate.

PIP MODE

Select the style of the PIP mode.

SWAP

Swap the main picture and sub picture when the PIP or POP mode is on. Change the video source for the PIP or POP sub picture. When chosen with one of the Component buttons, tells the VCR, CD or DVD player to pause.

ZOOM

Switch the zoom size to magnify the display to 2X, 4X image.

FREEZE

Freeze the picture. Note that the video and audio content will continue to change and when the button is pressed again, turning off the Freeze mode, the picture will not return to the same point as when it was frozen.

TV / DTV

Selects TV as the video source.

COMP

Alternately selects the component input COMP1 or COMP2.

HDMI / PC

Alternately selects the HDMI or PC inputs.

AV

Alternately selects the AV1, AV2 or AV3 inputs.

AV MODE

Preset AV Settings : STANDARD, MOVIE, GAME, USER-TV, DYNAMIC (FIXED), DYNAMIC.

PIP VIEW

Switch view mode of sub window to 16:9 or 4:3



Remote Control Operation

CAUTIONS :

- Do not drop or mishandle the remote control.
- Do not get the remote control wet. If the remote control gets wet, wipe it dry immediately.
- Avoid heat and humidity.
- When not using the remote control for a long period, remove the batteries.
- Do not take apart the batteries, heat them, or throw them into a fire.

Using the PIP Feature on the Remote Control

- Press the PIP button on the Remote Control to activate the PIP (Picture-In-Picture) mode. The PIP (sub screen) window will appear on the screen superimposed on the main screen. When you press this button again it will deactivate the PIP mode and the window will disappear.
- When the PIP window is visible, press the SWAP button and the main picture will switch to the PIP window and the PIP picture will replace it on the main screen. Press the SWAP button again and the pictures will switch back again.
- When the PIP window is visible, press the PIP MODE button and the RPTV will show the main and sub pictures as a split screen with the screen being divided equally between the two pictures but the content will be squeezed into the half width so that people will appear long and thin. Press the PIP MODE button again and will change to POP (Picture-Out-Picture) mode in which both pictures are equal again but this time the height is adjusted to match the width of each picture so that people are in the correct proportions. Press the PIP MODE button again and the format will change to PIP mode, which is where cycle of choices began.
- Press the INPUT button one or more times to select the video input desired.

Note: The RGB MODE, HDMI MODE, DTV MODE cannot be used as a sub picture source.

Programming the Remote Control

The TV Selection button has already been programmed to work with your RPTV (program code 0080). You can program the other seven Component buttons on the Remote Control to operate other components you have.

1. Turn "on" the component.
2. Choose a Component button you want to program, (for example CBL for a cable box or DVD for a DVD Player), on the Remote Control and press this button.
3. Press and hold the SETUP button until the LED on the Remote Control flashes twice.
4. Refer to the table on page 43 that lists components, and manufacturers and their relevant program codes to, Using the number buttons, enter the programming code. If the code is accepted the LED will flash twice after the last digit of the programming code is entered.
5. Point the Remote Control at the component and press the POWER button; the component should power off. If the component does not turn off and there is more than one programming code listed for the manufacturer and component, try the next code in the list for that manufacturer until you find the correct one.

Component Program Codes

Use the codes in Appendix page 43 to program the Remote Control to work with your existing audio and video components.

Searching for Component Codes

If you cannot find the manufacturer in the component list or the program code does not work, you can use the remote control to search for the correct component code.

1. Turn "on" the component.
2. Press the matching COMP button on the Remote Control
3. Press and hold the SETUP button until the LED flashes twice.
4. Press 9 9 1. After this number sequence has been entered the LED will flash twice.
5. Point the Remote Control at the component and alternate between pressing the POWER button and the COMP button on the remote control until the turns off. If the component still does not respond, clear the COMP button as described in the next three-step process, then repeat the search procedure.

Remote Control Operation

1. Make sure that the component is turned on.
2. Press and hold the SETUP button on the Remote Control until the LED flashes twice.
3. Press 9 9 2, then press the component button on the Remote Control twice.

Checking the Component Codes

If you have set up the Remote Control using the “Searching for Component Code” procedure, you may need to find out which four-digit code is operating your equipment.

To find out which code is operating your TV:

1. Press the TV button once.
2. Press the hold the SETUP button until the LED blinks twice, then release the SETUP button.
3. Enter 9 9 0. After this number sequence has been entered the LED will flash twice.
4. To view the code for the first digit, press 1 once. Wait 3 seconds, count the LED blinks (i.e., 3 blinks = 3) and write down the number.

Note: If a code digit is “0”, the LED will not blink.

5. Repeat step # 4 three more times for the remaining digits. Use 2 for the second digit. Use 3 for the third digit, and 4 for the fourth digit.
6. To check the codes for your other components, repeat steps 1 through 5, but substitute the appropriate key (i.e., AUX, CBL, VCR, SAT, CD, AMP, or DVD) for the component you are checking. As before, write down each four-digit code.

Reassigning COMP Buttons

You can reassign the COMP buttons on the remote control if you have more than one of the same type of component.

Example:

If you are using the Universal Remote to control your cable (CBL), CD, DVD, TV and two VCRs, you can reassign the satellite (SAT) button as a second VCR button.

1. Press and hold the SETUP button until the LED flashes twice.
2. Press 9 9 2. After this number sequence has been entered the LED will flash twice.
3. Press the COMP button that you want (VCR) once, and then press the COMP button that you are reassigning (SAT) once. The SAT button is now reassigned and can be programmed as a VCR component button. See “REMOTE CONTROL OPERATION” on page 21

Changing Volume Lock

The Remote Control is set to control the volume through your TV while in cable (CBL), DVD, satellite (SAT) and VCR component modes. Use the volume lock if you want to control the volume for all components through a specific component.

Example:

You want to control volume for all components through your tuner.

1. Press and hold the SETUP button until the LED flashes twice.
2. Press 9 9 3. After this number sequence has been entered the LED will flash twice.
3. Press the COMP button once that you want to control the volume (TNR). The LED flashes twice. Volume will now be controlled through the tuner for all components.

Teaching the Remote Control New Functions

The remote control can learn up to 25 additional functions from the component’s original remote control.

Remote Control Operation

Example:

Your DVD player remote control has a scan function that you may use frequently. There is not a scan button on the remote control. You can assign a button and use the DVD remote to teach the remote control the scan function.

1. Press and hold the SETUP button on the Remote Control until the LED flashes twice.
2. Press 9 7 5. After this number sequence has been entered the LED will flash twice.
3. Press the COMP button that you want to teach (DVD) once.
4. Press the button to which you want to assign the new function. The LED flashes quickly while it is waiting to receive the signal from the teaching remote.
5. Hold the teaching remote control approximately 1-inch (25mm) from the Remote Control making sure that the infrared ports are lined up, on the teaching remote press the button that you want the Remote Control to learn. The LED flashes twice.
6. Press the SETUP button to exit the learning mode.

Menu Functions

PICTURE

You can adjust the settings of the PICTURE(CONTRAST, BRIGHTNESS, COLOR, TINT, SHARPNESS , COLOR TEMP, NOISE REDUCTION, VIEW MODE.)

AUDIO

You can adjust the AUDIO settings. (TREBLE, BASS, BALANCE, EFFECT), for the internal SPEAKERS.

PIP SETUP

You can adjust the PICTURE IN PICTURE functions.

SETUP

You can set LANGUAGE, SPEAKER, CAPTION STYLE and input source settings.

PARENTAL CONTROL

PARENT CONTROL (V-CHIP)

- SECRET No.: You must set the password (SECRET No.) When using parental control functions.
- V-CHIP: This function allows you to restrict viewing of TV programs, to control TV usage based on FCC data and to prevent your children from watching content that may be deemed harmful.

OPTION

Special feature

- You can adjust the OSD position of horizontal and vertical and setup time-out
- MODEL NUMBER, MAIN INPUT, VIEW MODE, PIP INPUT, LAMP TIME and ID.

Getting Started

Turning your RPTV "On"

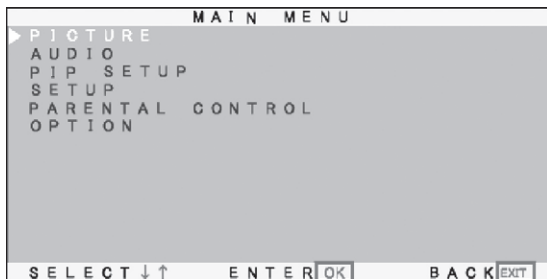

1. Plug the power cord into an AC wall socket. The POWER indicator on the front panel will light red.
2. Press the POWER button on the side panel or the POWER button on the Remote Control to power "on" the RPTV. The LAMP STATUS indicator will start flashing while the lamp heats up. Once the lamp is warm enough the indicator will stay lit green and the picture will begin to appear on the screen.
3. When the RPTV is "on", press the POWER button on the side panel or the POWER button on the Remote Control. A message will appear on the screen warning you that you are about to power "off" the RPTV. Once the RPTV has been turned "off" you cannot turn it "on" again until at least 30 seconds later as a protection feature for the lamp. The lamp could be damaged if it is turned "on" too soon after being "off". The LAMP STATUS indicator will start flashing until the protection time has passed and then the indicator will turn off and the RPTV will be in the standby mode.

Using the On Screen Display (OSD)

Menu Operations

The OSD consists of a Main Menu of items and each of these items has a Sub Menu associated with it that the OSD will switch to when the item is selected.

1. Press the MENU button on right side of the RPTV or remote control : The Main Menu will be displayed on the screen, as shown below.
2. Press the ADJUST ▲ (CH+) or ADJUST ▼ (CH-) button on right side of the RPTV or ▲ , ▼ buttons on the remote control to highlight the feature you wish to select.
3. Press the OK button on right side of the RPTV or remote control to select the feature. The Main Menu will now change to the Sub Menu of the feature selected.
4. Press the ADJUST ▲ (CH+) or ADJUST ▼ (CH-) button on right side or the ▲ , ▼ button of the RPTV on the remote control will highlight the option you wish to adjust and press the OK button on right side of the RPTV or on the remote control.
5. Adjust the level or change the setting of the selected option by pressing. ADJUST ► (VOL+) or ADJUST ◀ (VOL-) button on the right side of the RPTV or the ◀ , ► buttons on remote control.
6. Repeat steps 4 and 5 to adjust additional options.
7. Once the adjustment is complete press the “EXIT” button to return to the main menu or press the “MENU” button twice on right side of the RPTV or on the remote control to exit the OSD.

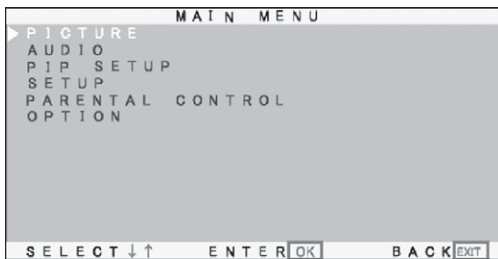

OSD Menus and Options

The OSD menus and options are used to adjust various settings on your RPTV.

PICTURE <DYNAMIC> – TV Modes

CONTRAST – Adjusts the contrast of the picture.

BRIGHTNESS – Adjusts the brightness of the picture. Users may need to adjust the brightness after the RPTV warms up.

COLOR – Adjusts the color saturation making colors more intense.

TINT – Adjusts the color of flesh tones.

SHARPNESS – Adjust the amount of detail enhancement.

COLOR TEMP – Adjust the color temperature level .

NOISE REDUCTION – Turns noise reduction “on” and “off”

VIEW MODE – Adjusts the screen width to STRETCH, SIDE BARS, SMART STRETCH, ZOOM, NORMAL, DOT BY DOT for viewing.

RESET – Return to default value.

PICTURE – PC Modes (RGB Input)

CONTRAST – Adjusts the contrast of the picture.

BRIGHTNESS – Adjusts the brightness of the picture. Users may need to readjust the brightness after the RPTV warms up.

- **H.POS:** Adjust the horizontal screen position.

- **V.POS:** Adjust the vertical screen position.

- **AUTO SYNC:** Automatically adjust to the best setting.

- **CLOCK:** Removes any vertical distortion and clears or sharpens the displayed characters.

- **PHASE:** Removes any horizontal distortion and clears or sharpens the displayed characters.

COLOR TEMP – Adjust the color temperature level .

RESET– Return to default value.

Using the On Screen Display (OSD)

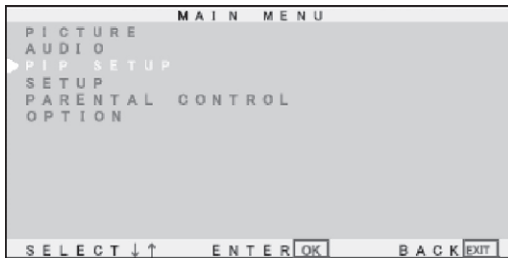

PIP SETUP

PIP MODE – Turns PIP mode on or off, or chooses four of the following pre-set modes: PIP, SPLIT, POP, OFF

- **PIP** : Start the Picture in Picture and option sub function
- **SPLIT** : The screen is divided in half. The left side is the main picture and the right side is the sub-picture.
- **POP** : The screen is in the 16:9 mode and divided in half. The left side is the main picture and the right side is the sub-picture.
- **OFF** : Turns “OFF” PIP function.

VIEW MODE : Changes the sub-picture size. Choose between 4:3 and 16:9.

SIZE : Changes the size of the sub-picture.

H POS. : Moves the sub-picture left or right.

V POS. : Moves the sub-picture up or down.

TRANSPARENCY : Adjusts the sub-picture transparency.

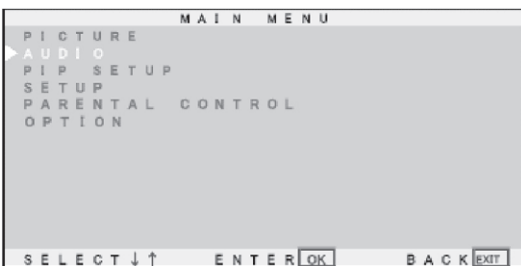

AUDIO ADJUST

TREBLE – Adjust the treble.

BASS – Adjusts the bass.

BALANCE – Adjusts the balance level between the speakers.

EFFECT – Adds simulated audio effects. Switch between BBE, SURROUND, SIM.STEREO.

RESET– Return to default value.

Note:

The BBE audio effect reproduces the original live performance of the music that is amplified through loudspeakers for a fuller and more “life-like” sound stage.



SETUP

LANGUAGE - Allows you to select between ENGLISH, SPANISH and FRENCH from the ON SCREEN DISPLAY.

MTS - Change the sound output for TV programs. Switch between STEREO, SAP or MONO.

SPEAKER - You can use your RPTV as a center channel speaker “ON” or “OFF”

- **SP ON**: Audio from built-in speakers.
- **CENTER-IN**: You can use your RPTV as a center channel speaker but cannot adjust volume or mute.
- **SP OFF**: You can select SPEAKER “off” to mute the audio.

CLOSED CAPTION - Turns closed captioning “on” and “off”.

CAPTION MODE - Sets the display mode for closed captioning. (For analog channels only)

DTV SETUP - For DTV source only

- **CH SETUP (DTV)**

- **CH SEARCH (DTV)**: Automatically searches for DTV channels.
- **MANUAL SEARCH**: Manually searches for DTV channels parenthesis
- **EDIT**: Edit channel for parenthesis.



Using the On Screen Display (OSD)

- **CLOSED CAPTION (DTV):** Sets the display mode and style for closed captioning.
- **AUDIO (DTV)**
 - **AUDIO :** You can choose any language or any sound effects on this option.
 - **AUDIO SETUP :** You can setup your Digital Audio Output sound effects to DOLBY DIGITAL or PCM.
- CH SETUP -** AIR/ CABLE antenna option first and you can select channel search by auto or manual.
- HDMI SIGNAL -** Use on single HDMI cable for difference source input.
- HDMI AUDIO -** Use on DVI cable without audio function and connect additional audio cable.
- INPUT SIGNAL -** Use on RGB source timing selection.

- When RGB source signal input and the timing is 640X400, 720X400, 640X480 and 720X480 you need to switch to compatible option.
- When starting in the PIP mode the DTV function is not available.

6.

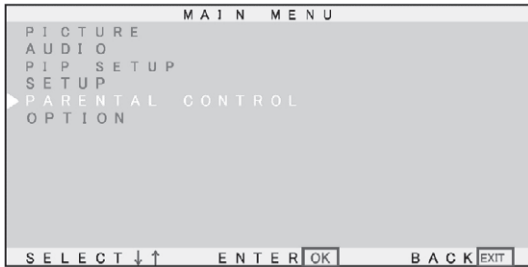

7.

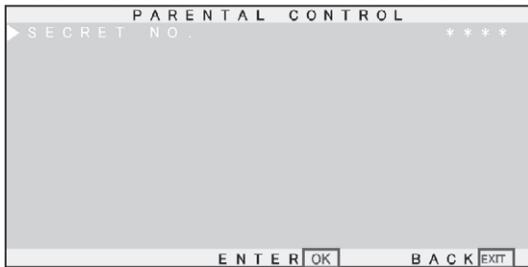

8.

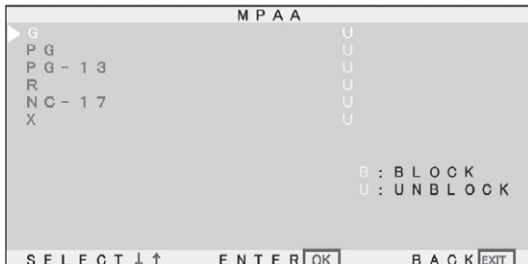
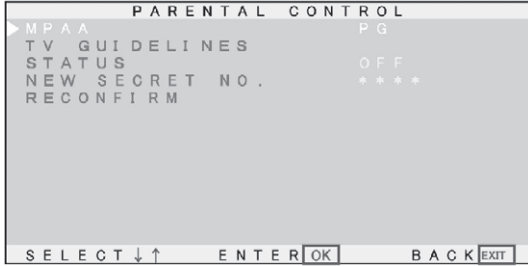

PARENTAL CONTROL (V-CHIP)

The Parental Controls feature prevents viewers from watching programs that are not age-appropriate, such as programs containing violence or adult language.

1. Press the TV button on the remote control.
2. Press the MENU button on the Remote Control and the Main Menu will be displayed on the screen, as shown below.
3. Press the ▲, ▼ button to select “PARENTAL CONTROL”.
4. Press the OK button and the SECRET number.
5. Press the OK button to change password.
6. Enter your idea number. If you have not set a new number, use the number button pad to enter 0000. For more information about setting a password, see “Setting a password” on page 29.
7. Press the OK button to open M P A A Rating.
8. Press the ▲, ▼ buttons to select which rating you want to block or unblock. You can select from the following ratings:
 - G (General audience)
 - PG (Parental guidance suggested)
 - PG-13 (Recommended for children 13 years of age and older)
 - R (mature audience)
 - NC-17 (no one under 17 years of age)
 - X (no one under 17 years of age)
9. Press the OK button to select U (unblocked) or B (blocked).
10. Press the EXIT button to return to “PARENTAL CONTROL” menu.
11. Press the ▲ or ▼ button to select “TV GUIDELINES” menu.

Using the On Screen Display (OSD)

11.

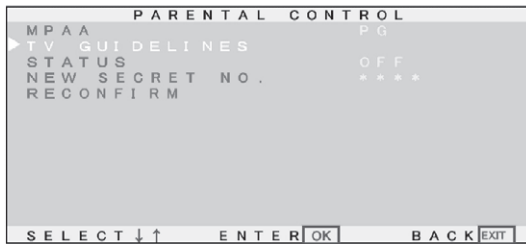

13.

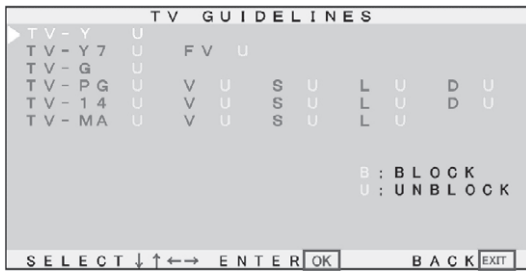

19.

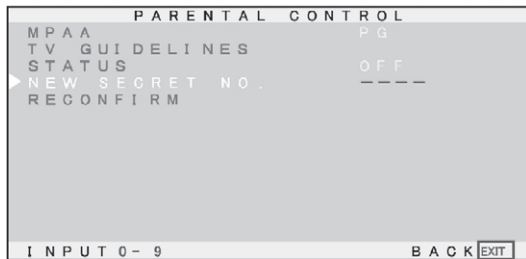

22.

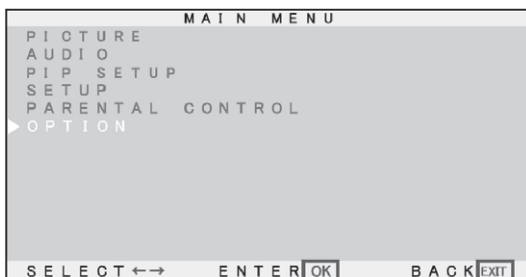
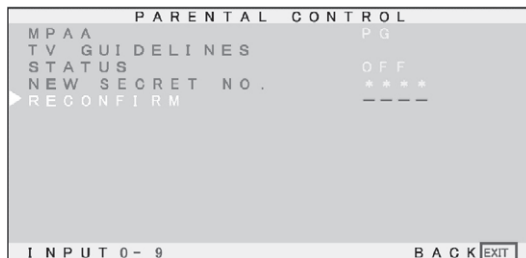

12. Press the OK button to open the “TV GUIDELINES” menu.

13. Press the ▲, ▼, ◀, ▶ buttons to select which rating you want to block or unblock. You can select from the following ratings:

- TV-Y (all children)
- TV-Y7 (older children)
- TV-G (general audience)
- TV-PG (guidance suggested)
- TV-14 (strongly cautioned)
- TV-MA (mature audience)

You can customize these ratings for:

- FV (fantasy violence)
- V (violence)
- L (adult language)
- S (sexual situations)
- D (sexual dialog)

14. Press the OK button to select U (unblocked) or B (blocked).

15. Press the EXIT button to return to “PARENTAL CONTROL” menu.

16. Press the ▲ or ▼ buttons to select “STATUS”.

17. Press the OK button to select “ON” or “OFF” and ◀, ▶ button to enable or disable this function.

18. Press OK button to return.

19. Press the ▲ or ▼ buttons to select “NEW SECRET NO.”.

20. Press the OK button to open “NEW SECRET NO.” option.

21. Enter your idea number setup your password.

22. Enter the number again to “RECONFIRM” your password.

23. Press the EXIT button repeatedly to exit the OSD.

OPTION

OSD H POSITION – Adjusts the horizontal position of the OSD within the display image.

OSD V POSITION – Adjusts the vertical position of the OSD within the display image.

SYSTEM INFO – Displays current system information

RESET ALL SETTINGS – Resets all settings, except the parental controls, to the factory defaults.

SLEEP TIMER – Turns sleep timer on and off and selects the number of minutes the RPTV waits before it automatically turns off. You can specify 30, 60, 90, or 120 minutes.

Setting a Password

You control access to the Parental Control features with a password. The default password is 0000. You can change the password to any four-digit number.

To change the password:

1. Press the TV button on the remote control.
2. Press the MENU button on the Remote Control and the Main Menu will be displayed on the screen, as shown below.
3. Press the ▲ or ▼ button to select "PARENTAL CONTROL".
4. Press the OK button and the Main Menu will now change to the "PARENTAL CONTROL" sub menu.
5. Press the OK button again to select SECRET NO..
6. Enter your password. If you have not set a password, use the number button pad to enter 0000.
7. Press the ▲ or ▼ button to select NEW SECRET NO..
8. Press the OK button and enter new secret number.
9. Enter the new password again when prompted RECONFIRM.
10. Press the EXIT button repeatedly to exit the OSD.

To reset your password:

1. Press the TV component button.
 2. Press the MUTE button on the Remote Control.
 3. Press the DISP. button, then press the ▲, ▼, ◀, ▶ and OK buttons within 4 seconds. SECRET NO. RESET message appears. Your password has been reset to 0000.
- The new password setting please refer to above procedure of **To change the password**.

Television Antenna Connection Protection

External Television Antenna Grounding

If an outside antenna or cable system is to be connected to the RPTV, make sure that the antenna or cable system is electrically grounded to provide some protection against voltage surges and static charges. Please refer to the operating or operation manual of your antenna or cable system for further information.

Article 810 of the National Electrical Code, ANSI/NFPA 70, provides information with regard to proper grounding of the mast and supporting structure, grounding of the lead-in wire to an antenna discharge unit, size of grounding conductors, location of antenna discharge unit, connection to grounding electrodes, and requirements for the grounding electrode.

Lightning Protection

For added protection of the RPTV during a lightning storm or when it is left unattended or unused for long periods of time, unplug the RPTV from the wall outlet and disconnect the antenna or cable system.

Power Lines

Do not locate the antenna near overhead light or power circuits, or where it could fall into such power lines or circuits.

Using Wide Modes: View Mode

Wide screen mode allow you to change the aspect ratio on screen. You can press the VIEW MODE button on the REMOTE CONTROL to change the aspect ratio on screen.

Press VIEW MODE

1. The View mode menu displays.
2. The menu lists the view mode options selectable for the type of video signal currently received.
3. Press VIEW MODE or ▲ or ▼ while the VIEW MODE menu is still on the screen.
4. You can sequentially select a view mode that has its own aspect ratio.

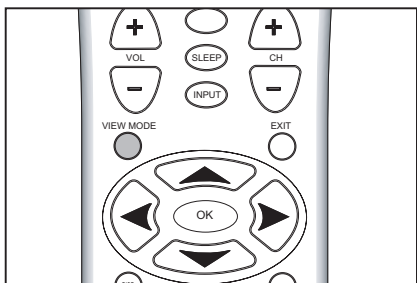

View mode for 4:3 programs:

Side Bar	S.Stretch	Zoom	Stretch
Suitable for viewing conventional 4:3 programs in their normal format.	Suitable for stretching 4:3 programs to fill the screen. (SMART-STRETCH)	Suitable for viewing wide-screen 2.35:1 nongraphic DVD in full screen.	This mode is useful for 1.78:1 DVDs. When viewing 1.85:1 DVD, stretch mode will still show very thin black bands at the top and bottom of the screen.

View mode for PC input mode:

Normal	Zoom	Stretch	Dot by Dot
Keeps the original aspect ratio in a full screen display.	Keeps the original aspect ratio in a full screen display. The top and bottom of the image is slightly cropped.	An image fully fills the screen.	Detects the resolution of the signal and displays an image with the same number of pixels on the screen.

Note:

- VIEW MODE is not available when using the POP, SPLIT functions.
- When STRETCH mode is available, You can use 720p and 1080i signal input through HDMI or component terminal.

Cleaning & Maintenance

Cleaning the Screen

The screen of the RPTV has been specially treated. To clean, users should wipe the surface gently using only a cleaning or a soft, lint-free cloth. If the surface is particularly dirty, use a little water on the cloth (never directly on the screen), then wipe the screen with it.

Reminders:

- Do not use substances such as glass cleaners, solvents and/or thinners.
- Do not scratch or hit the surface of the screen with fingers or any hard objects.

The screen of the RPTV is made of specially coated plastic and can be scratched or damaged by abrasive or ammonia-based window cleaners. Scratches on the bezel or screen are not covered by the warranty.

Cleaning the Exterior

The RPTV is cooled by air circulated through the vents in the case so for optimized performance, keep the vents clear of dust. To clean, turn off and unplug the RPTV, then brush the dust away from the vents with a damp cloth. Be careful not to drip any water into the vents.

Reminders:

- Do not attempt to clean dust from the inside of the RPTV.
- Do not use abrasives or solvent cleaners because they can damage the finish on the components.
- Do not allow any excessive water or moisture to come into contact with the surface of the DLP TV. If water or moisture gets inside the RPTV, operating problems and electrical hazards may result.
- Do not scratch or hit the surface of the screen with fingers or any hard objects.
- Do not place articles made of rubber or PVC near the cabinet for any extended periods of time.

Replacing the Lamp

The projection lamp has a limited life which illuminates the picture.

If the screen becomes dark, the color looks unusual, or the Lamp LED indicator on the front of the RPTV lights the screen shows message of "PLEASE REPLACE THE LAMP", it is time to replace the lamp with a new one (not supplied)

(Users should replace the lamp in the television approximately every 6,000 hours to maintain the best possible image quality. Do not use a lamp past the rated lamp life.) The high-pressure lamp may explode if handled incorrectly. Make sure that the RPTV is turned off, power is disconnected, and the lamp is completely cooled (minimum of 45 minutes) before replacing it. Use only SHARP replacement lamps listed below for Replacement. Use of any other lamps may cause damage to the RPTV.

1. Turn off your RPTV
2. Disconnect the power cord and all other external cables.
3. Allow the lamp to cool completely at least 45 minutes.
4. Remove the lamp access panel screw and remove the access panel.
5. Remove the two lamp module retaining screws.
6. Use the lamp removal handle to lift the lamp module straight out of the lamp bay.
7. Replace the lamp module into the lamp bay. Make sure not to touch the lamp. The oils from hands can cause the lamp to fail prematurely.
8. Replace the two lamp module retaining screws. Make sure that the screws are fastened securely to make sure that the lamp will not shake. Safely discard the used lamp (see page iii about the lamp disposal).
9. Replace the lamp bay access panel, and then replace the access panel screw.
10. Connect the power cable and all external cables.
11. Reset the lamp timer. Please refer to page 34 "Resetting the lamp timer"

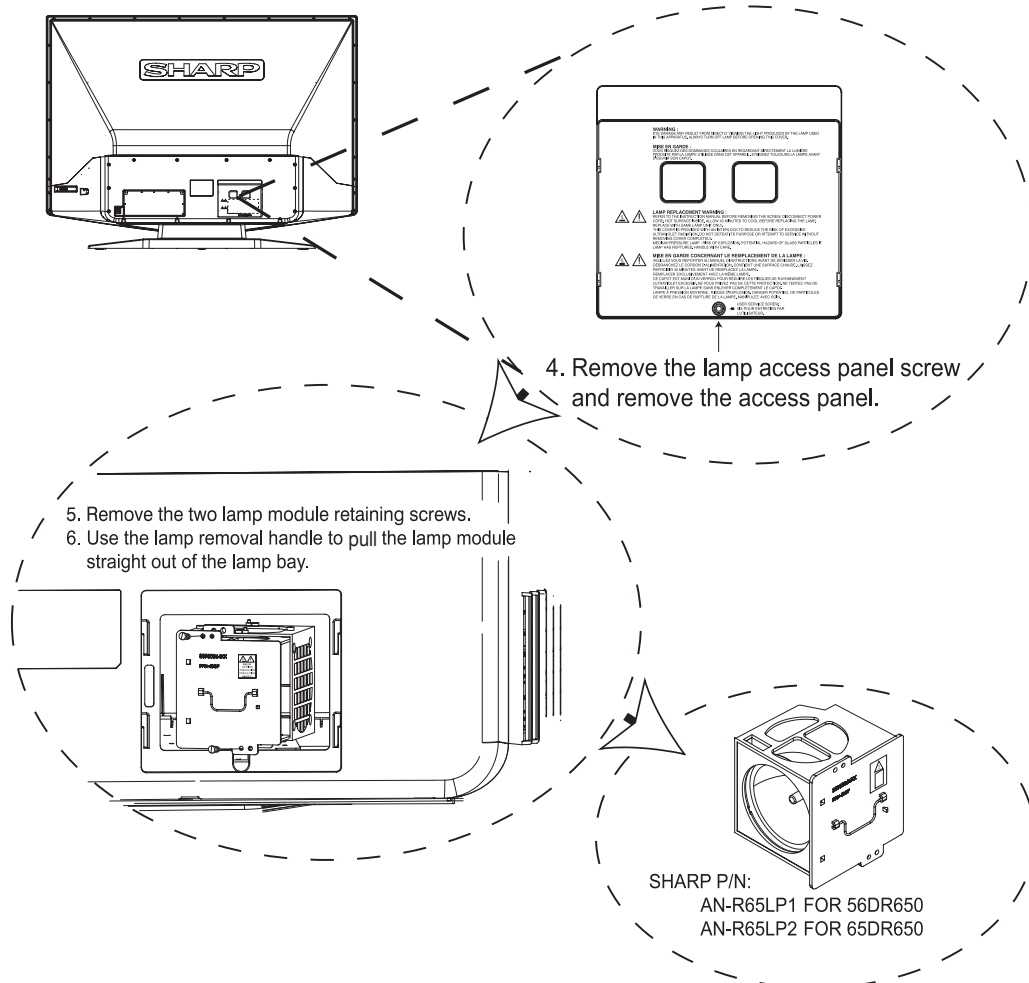

Replacing the Lamp

- When the “Lamp Replacement” warning appears on screen it is time to replace the lamp. (Lamp LED warning light will appear red).
- Press “OK” to make the warning disappear.
- After replacing the lamp please reset the lamp timer.
- Make sure to reset the lamp timer only when replacing the lamp. If you reset the lamp timer and continue to use the same lamp this may cause the lamp to explode.
- To Reset Lamp Timer please follow these steps:
 - 1.) Press “MENU” and “VOL ADJ +” buttons on the right hand side of the RPTV for three 3 seconds while the RPTV is on.
 - 2.) ”Lamp Timer Reset” should appear on screen.
 - 3.) Press “OK” to reset the lamp timer.

Status LEDs

There are two status LEDs on the front of the RPTV.

State	Power LED	Lamp LED	Description
AC off	Not lit	Not lit	AC power is not connected
Standby mode	Red	Not lit	AC power is connected and the RPTV is in standby mode.
Warm-up	Green	Flashing Red	AC power is connected and the power button has just been turned on.
Operation mode	Green	Not lit	AC power is connected, the power button has been pressed and the lamp has warmed up.
Cool down mode	Red	Flashing Red	AC power is connected and the power button has just been turned off.
Lamp caution	Green	Red	Lamp life has ended. Please Replace the lamp.

ERROR MESSAGE

Error Code	Power LED	Lamp LED	Description
21	Flashes green twice, then Red once.	Not lit	One of the cooling fans has failed.
32	Flashes green three times, then twice.	Flashing Red	Indicates lamp trouble or failure. The RPTV will automatically shut down and restart itself.
52	Flashes green five times, then Red twice.	Not lit	Indicates hardware error. Power off the RPTV, wait one minute, and then restart the RPTV.

Troubleshooting Guide

Use the following information to solve common problems.

Symptom	Possible Solutions
No picture	<p>Make sure that the power cord is plugged into a grounded electrical outlet.</p> <p>Make sure that the Power button is turned on.</p> <p>Look in the left air vent to see if the lamp is on.</p> <p>Make sure that the selected input source is connected to a working component. If the other component is not working, correct the problem with the other component.</p> <p>If the RPTV is connected to a computer in RGB mode check to see if the computer has gone to sleep and if so, press any key on the keyboard to “wake up” the computer.</p>
The picture is distorted or there is an unusual sound.	<p>Check if there is interference from other electrical appliance, car, motorcycle or fluorescent light. Try moving the RPTV or offending appliance to another location.</p>
The color is abnormal.	<p>Check that the input source cable is connected securely and correctly to the back of the RPTV.</p>
There are abnormal patterns on the picture.	<p>Check that the input source cable is connected securely and correctly to the back of the RPTV.</p> <p>Make sure that the video input source is within the range of the RPTV. Compare the video input source’s specifications with the RPTV specifications.</p>
The picture does not fill the whole screen.	<p>If the TV, AV1, AV2 or component is being used with normal 480i input, VIEW MODE button on the remote control to scroll through various screen modes. (page 31)</p>
There is a picture but no sound.	<p>Make sure that the volume is not turned down.</p> <p>Make sure that the sound is not Muted.</p> <p>Make sure that the internal speakers are not turned off.</p> <p>Make sure that the audio input source cables are connected securely and correctly.</p>
The RPTV has pixels that are always dark.	<p>The RPTV is manufactured using an extremely high level of precision technology. However, sometimes pixels may not display. Pixel defect within the industry specifications are inherent to this type of product and do not constitute a defective product.</p>
There is video noise or artifact on the picture.	<p>When the RPTVs digital capabilities exceed a digital broadcast signal, the signal is up-converted (increased) to match the RPTVs display capabilities. This process may cause video noise or artifact on screen.</p>

Symptom	Possible Solutions
Screen brightness is diminished.	<p>Video display components experience degradation of brightness over the life of the component. Normal brightness degradation is not covered by the warranty.</p> <ul style="list-style-type: none"> • Check brightness setting • Check lamp timer • Replace lamp
The LED on the Remote Control does not blink when a button is pressed.	Replace the batteries with two "AA" new alkaline batteries. See "Inserting batteries" on page 4.
The Remote Control LED blinks when a component selection button is pressed, but the component does not respond.	<p>You make sure that there are less than 15 feet (4.5 meters) from the infrared remote sensors on the component. Nothing is blocking the infrared remote sensors on the remote control or the component.</p> <p>You have chosen the correct component selection button. The remote is programmed for that component. See "REMOTE CONTROL OPERATION" on page 21.</p> <p>Check that the component's original remote control will operate the component.</p>
The Remote Control does not control home entertainment components or commands are not working properly.	<p>Try all listed codes for the component brands being set up. (Page 43)</p> <p>Make sure they can be operated with an infrared remote control.</p>
TV/VCR Combo does not respond to the Remote Control properly.	Use the VCR codes for your brand. Some combo units may require both a TV code and a VCR code for full operation. (Page 43)
No volume on a 2nd TV.	Follow instructions for "Changing Volume Lock", see page 22.
Changing channels does not work properly with the Universal Remote Control.	If original remote control required change channels does not work properly, press ENTER on the universal remote after entering the channel number.
The Remote Control does not work.	<p>Check the Remote Control batteries replace them with new AA batteries if necessary.</p> <p>Make sure that nothing is blocking the infrared remote sensors on the remote control or the RPTV.</p>

Specifications

Model	56DR650 65DR650
Optical System	Texas Instruments HD3 0.55 inch DLP™ DMD - Resolution 720P (Progressive)
Screen size	56DR650 : 56 inches Diagonally 65DR650 : 65 inches Diagonally
Channel Coverage	
VHF	2-13
UHF	14-69
DTV	1-999
CATV	1-125
Lamp	56DR650 = AC 120W 65DR650 = AC 135W
Television System	NTSC - National Television Standards Committee ATSC - Advanced Television Systems Committee
Input & Output	<p><u>Right Side Input :</u> Audio/Video in: (S-Video, Video, Audio-L/R) x 1</p> <p><u>Rear Side Inputs/Outputs :</u> Antenna in: Analog x 1, Digital x 1 Component in: (Y, PB, PR, Audio-L/R) x 2 Audio/Video in: (S-Video, Video, Audio-L/R) x 2 Digital Audio Output (for ATSC only): Coaxial x 1, Optical x 1 Special Audio Input: Center Channel Input x 1 HDMI Input: (HDMI, Audio-L/R) x 1 PC Input: (RGB, Audio-stereo) x 1 Service Control Input: RS232 x 1</p>
HDMI	The HDMI (High Definition Multi-Media Interface) for connection with HDMI enabled SET TOP BOXES. HDMI enables the RPTV to support signals of 480p, 720p and 1080i. Users can also purchase a HDMI to DVI cable to connect with AV equipment that has a DVI connection.
Speakers	8 Ohm 15w x2 : 30W total
Power Source	AC 120 V, 60Hz
Power Consumption	275W (1W standby with AC 120V) (56DR650) 300W (1W standby with AC 120V) (65DR650)
Dimensions (W x D x H)	56DR650 51 1/2" [1312mm] × 15 1/2" [399mm] × 42 1/2" [1076mm] 65DR650 59 1/2" [1512mm] × 18 " [459.5mm] × 47" [1200mm]

Specifications

Weight	56DR650 130 Lbs (59 Kg) 65DR650 143.3 Lbs (65 Kg)
Supplied Accessories	
Remote Control	Part Number : 9NK5041809200
AA Batteries	x2 for Remote Control
Optional Accessories	AN-R65LP1-Replacement Lamp for 56DR650 AN-R65LP2-Replacement Lamp for 65DR650

- As part of policy of continuous improvement, SHARP reserves the right to make design and specification changes for product improvement without prior notice. The performance specification figures indicated are nominal values of production units. There may be some deviations from these values in individual units.

Dimension

56DR650

UNIT: inch / [mm]

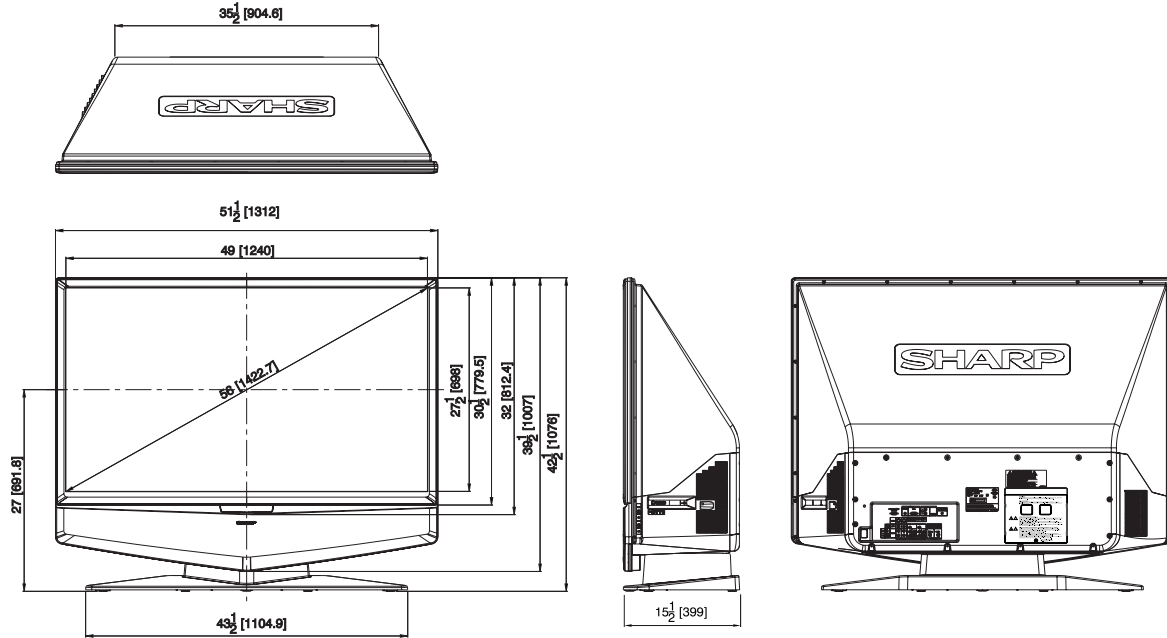

65DR650

UNIT: inch / [mm]

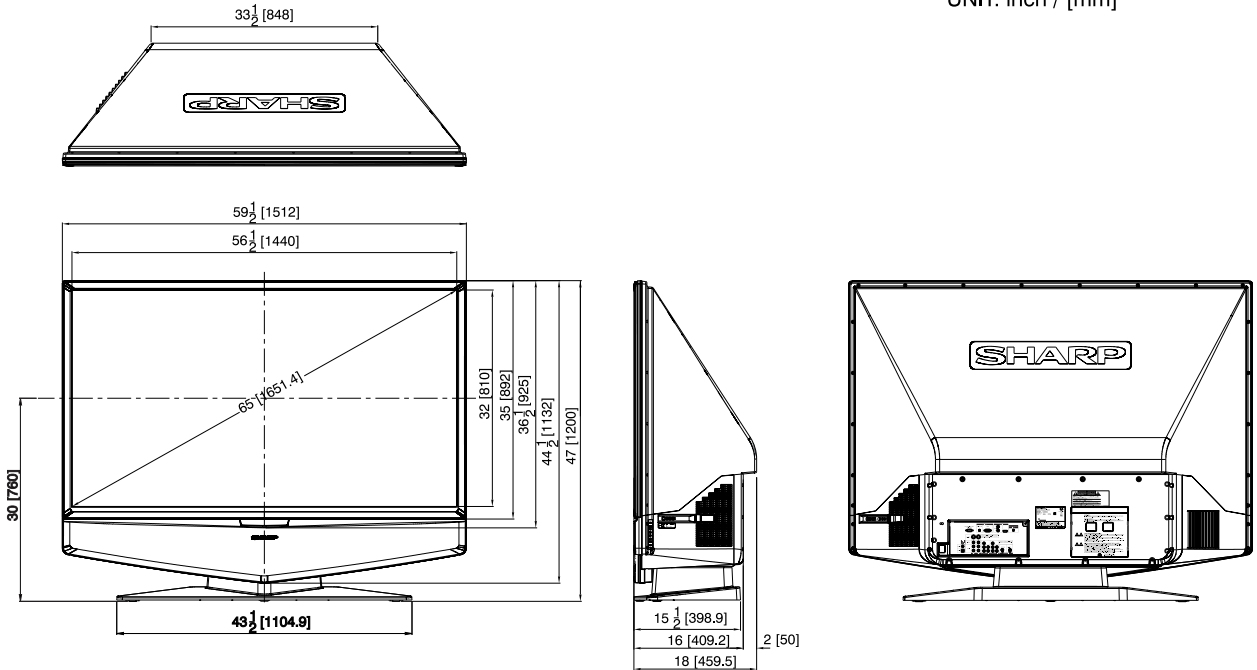

Input / Output Terminals and Connectable Equipment

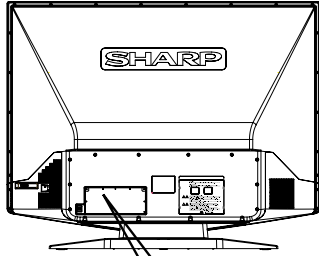

RGB TERMINAL
Connecting the computer to display the PC MODE (See page 12)

HDMI TERMINAL
Connecting video equipment with DVI and HDMI input terminal (DVD player, STB etc.). (See page 8)

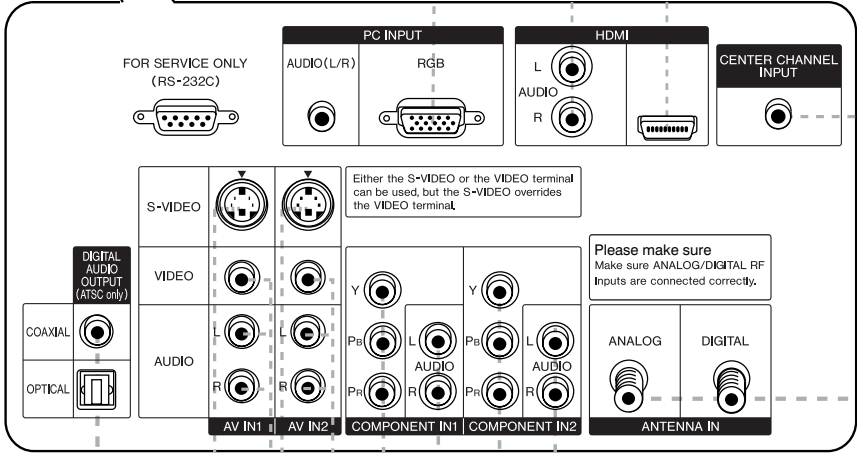

CENTER CHANNEL INPUT
(See page 14)

DTV CHANNEL AUDIO OUTPUT
(SEE page 15)

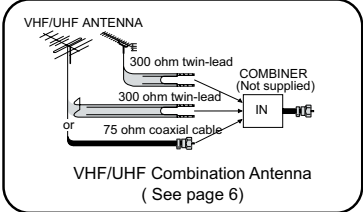

AV IN1, AV IN2 TERMINAL
Connecting video equipment with AV output terminal (DVD player, etc.). (See page 7)

COMPONENT IN1, IN2 TERMINAL
Connecting video equipment with Component output terminal (DVD player, STB etc.). (See page 10)

Index

A

AMP button(Remote Control)	18
AUDIO	24, 26
AUDIO (DTV)	26
AUDIO ADJUST	26
Audio Cable	10, 26
Audio input terminal	7
Audio Output	15
AUDIO SETUP	26
Auto Sync adjustment	25
AUTOSYNC	13
AUX button (Remote Control)	18
AV button (Remote Control)	20
AV MODE button (Remote Control)	20

B

BALANCE	26
BASS	26
Battery	4
BRIGHTNESS	25

C

CAPTION STYLE	26
CBL button (Remote Control)	18
CD button (Remote Control)	18
Center Channel Input	14
CENTER-IN	26
CH button (Remote Control)	18
CH SEARCH (DTV)	26
CH SETUP (DTV)	26
Change Password	29
Changing Volume Lock	21
Channel +/- & Adjust button (Side Control Section)	16
Channel +/- Button	16, 18
Checking Component Codes	21
Cleaning the Exterior	32
Cleaning the Screen	32
Clock (PC mode only)	25
CLOSED CAPTION	26
CLOSED CAPTION (DTV)	26
Coaxial cable	6
COLOR	25
COLOR TEMP	25
COMP button (Remote Control)	20
Component Cable	7, 10
Component Codes	27
Component Program Codes	21, 26
Composite Cable	9
CONTRAST	25

D

Digital Audio Output	15
Digital Video	8
DISP. button (Remote Control)	19
Dot by Dot	31, 39
DTV SETUP	26
DVD button (Remote Control)	18
DVI cable	8

E

EDIT	26
EFFECT	26
ENTER button (Remote Control)	18
ERROR MESSAGE	34
EXIT button (Remote Control)	19

F

FLASHBACK button (Remote Control)	18
FREEZE button (Remote Control)	20
Front Panel Indicator	17
F-type connector	6

G

Game console connecting	11
Getting Standard	24

H

H POS	25, 26
HDCP	12
HDMI	8
HDMI AUDIO	26
HDMI SIGNAL	26
HDMI Terminal	8
HDMI/PC button (Remote Control)	20

I

IN AV3 Button	11
Input / Output Terminals	40
INPUT button (Remote Control)	16, 18
INPUT button(Side Control Section)	16
INPUT SIGNAL	26

L

LAMP LED	17
LANGUAGE	26
Lightning Protection	30

M

MANUAL SEARCH	26
MENU & EXIT button (Side Control Section)	16
MPAA Rating	27
MTS	26

Index

MUTE button (Remote Control) -----	19	SIZE -----	26
NEW SECRET NO. -----	27	SLEEP button (Remote Control) -----	18
NOISE REDUCTION -----	25	SLEEP TIMER -----	28
Normal -----	31	SP OFF -----	26
Number Pad button (Remote Control) -----	18	SP ON -----	26
O		SPEAKER -----	26
OFF -----	26	SPLIT -----	25, 26
OK button (Remote Control) -----	19	STATUS -----	28
OK button (Side Control Section) -----	16	Status LEDs -----	34
On Screen Display (OSD) -----	25	Stretch -----	31
Optical Terminal -----	15	S-VIDEO Cable -----	7,9
OPTION -----	24, 28	SWAP button (Remote Control) -----	20
P		SYSTEM INFO -----	28
PARENTAL CONTROL -----	24	T	
PC Compatibility -----	13	TINT -----	25
PC INPUT -----	12	TRANSPARENCY -----	25, 26
PHASE (PC mode only) -----	25	TREBLE -----	26
PICTURE -----	24, 25	TV button (Remote Control) -----	18
PIP -----	25, 26	TV GUIDELINES -----	27
PIP button (Remote Control) -----	20	TV/DTV button (Remote Control) -----	20
PIP MODE button (Remote Control) -----	20	V	
PIP SETUP -----	21, 24	V POS -----	25, 26
PIP VIEW button -----	25	VCR button (Remote Control) -----	18
PIP VIEW button (Remote Control) -----	20	VIEW MODE -----	25, 31
POP -----	26	VIEW MODE button (Remote Control) -----	19
POWER button (Remote Control) -----	18	VOL button (Remote Control) -----	18
POWER button (Side Control Section) -----	16	VOLUME +/- & ADJUST button -----	16
POWER LED -----	17	W	
R		Wide Modes -----	31
RECONFIRM -----	28	Z	
Remote Control -----	14	Zoom -----	31
Remote Control Sensor -----	17	ZOOM button (Remote Control) -----	20
Remote LED -----	18		
Replacing the Lamp -----	33		
RESET -----	25, 26		
RESET ALL SETTINGS -----	28		
Reset Password -----	29		
Resetting the lamp timer -----	34		
S			
S.Stretch -----	31		
SAT button (Remote Control) -----	18		
Searching for Component Codes -----	21		
SELECT button (Remote Control) -----	20		
Setting Password -----	29		
SETUP -----	24, 26		
SETUP button (Remote Control) -----	18		
SHARPNESS -----	25		
Side Bar -----	31		

APPENDIX:

Remote Control IR Set Up Codes

MANUFACTURER'S CODES

AMPLIFIERS

GE	0078
Harman/Kardon	0892
JVC	0331
Marantz	0892
Optimus	0395
Philips	0892
PolkAudio	0892
Realistic	0395
Sony	0689
Soundesign	0078
Victor	0331
Wards	0078
Yamaha	0354

CABLE

ABC	0003,0017
Americast	0899
BellSouth	0899
GeneralInstrument	0276,0476,0810
GoldStar	0144
Hamlin	0009,0273
Jerrold	0003,0276,0476,0810
Memorex	0000
Motorola	1106
Pace	0237
Panasonic	0107,0000
Paragon	0000
Philips	0305,0317
Pioneer	0144,0533,0877
Pulsar	0000
Quasar	0000
Regal	0273,0279
Runco	0000
Samsung	0144
ScientificAtlanta	0017,0477,0877
Starcom	0003
Toshiba	0000
Zenith	0000,0525,0899

CD PLAYERS

Aiwa	0157
Burmester	0420
CaliforniaAudioLabs	0029
Carver	0157,0179
DKK	0000
Denon	0003,0873
Emerson	0305
Fisher	0179
Garrard	0420
Genexxa	0032,0305
Harman/Kardon	0157,0173
Hitachi	0032
JVC	0072
Kenwood	0028,0190,0826,0037,0626,0681
Krell	0157
LXI	0305

Linn	0157
MCS	0029
MTC	0420
Magnavox	0157,0305
Marantz	0157,0626,0029
Mission	0157
NSM	0157
Onkyo	0101,0868
Optimus	0032,0468,0420,0179,0305,1063,0000,0037,0145
Panasonic	0029
Parasound	0420
Philips	0157,0626
Pioneer	0032,0468,0305,1062,1063
PolkAudio	0157
Proton	0157
QED	0157
Quasar	0029
RCA	0053,0032,1062,0468,0305,0179
Realistic	0179,0420
Rotel	0157,0420
SAE	0157
Sansui	0157,0305
Sanyo	0179
Scott	0305
Sears	0305
Sharp	0037,0861
Sherwood	1067
SonicFrontiers	0157
Sony	0000,0490
Soundesign	0145
Tascam	0420
Teac	0420
Technics	0029
Victor	0072
Wards	0053,0157
Yamaha	0036,0888

HOME AUTOMATION

GE	0240
OneForAll	0167
RadioShack	0240
SecuritySystem	0167
UniversalX10	0167

VIDEO

Panasonic	1120
Pioneer	1010
SensoryScience	1126
Sharp	1010

RECEIVERS

ADC	0531
Aiwa	0121,1405,1089
Capetronic	0531
Carver	1089,1189

Denon	1160,1104
Harman/Kardon	0110
JBL	0110
JVC	0074
Kenwood	1027,0186,1313,1569,1570
MCS	0039
Magnavox	1089,0531,1189
Marantz	1189,1089,0039
Onkyo	0135
Optimus	1023,0186,0531,0670
Panasonic	0039,1518
Philips	1089,1189,1269
Pioneer	0150,0531,0630,1023
Proscan	1254
Quasar	0039
RCA	1254,0531,1023
Sansui	1089
Sharp	0186
Sony	1158,1058,1258
Soundesign	0670
Sunfire	1313
Technics	0039,1308,1518,1309
Thorens	1189
Victor	0074
Yamaha	0176,0186,1176

SATELLITE

AlphaStar	0772
Chaparral	0216
Echostar	0775,1005
Expressvu	0775
GE	0566
GeneralInstrument	0869
HTS	0775
Hitachi	0819
HughesNetworkSystems	0749,1142,1749
JVC	0775
Magnavox	0722,0724
Memorex	0724
Mitsubishi	0749
NextLevel	0869
Panasonic	0247,0701
Philips	1076,1142,0722,0724,0749
Proscan	0392
RCA	0566,0392,0143,0855
RadioShack	0869
Samsung	1109
Sony	0639
StarChoice	0869
Toshiba	0749,0790
Uniden	0724,0722
Zenith	0856

TELEVISION

AOC	0019,0030
Admiral	0093,0463
Aiko	0092
Aiwa	0701
Akai	0030
Alaron	0179

AmericaAction ----- 0180
 Anam ----- 0180
 Audiovox ----- 0092,0180,0451,0623
 Baysonic ----- 0180
 Belcor ----- 0019
 Bell&Howell ----- 0016,0154
 Bradford ----- 0180
 Brockwood ----- 0019
 Broksonic ----- 0236,0463
 CXC ----- 0180
 Candle ----- 0030,0056
 Carnivale ----- 0030
 Carver ----- 0054
 Celebrity ----- 0000
 Cinal ----- 0451,0092
 Citizen ----- 0056,0030,0060,0092
 Concerto ----- 0056
 Contec ----- 0180
 Craig ----- 0180
 Crosley ----- 0054
 Crown ----- 0180
 CurtisMathes 0060, 0030, 0016, 0047, 0051, 0054,
 0056, 0093, 0145, 0154, 0166, 0451, 1147, 1347
 Daewoo ----- 0092,0623,0019,0624,0451
 Daytron ----- 0019
 Denon ----- 0145
 Dumont ----- 0017,0019
 Electroband ----- 0000
 Emerson 0236,0180,0178,0179,0463,0624,0623
 ,0019,0154
 Envision ----- 0030
 Fisher ----- 0154
 Fujitsu ----- 0179,0683
 Funai ----- 0180,0171,0179
 Futuretech ----- 0180
 GE 0047,1347,0051,0178,0451,1147,0093
 Gibraltar ----- 0017,0019,0030
 GoldStar ----- 0178,0019,0030,0056
 Gradiente ----- 0056,0053
 Grunpy ----- 0179,0180
 Hallmark ----- 0178
 HarleyDavidson ----- 0179
 Harman/Kardon ----- 0054
 Harvard ----- 0180
 Hitachi ----- 0145,0056,0016
 Infinity ----- 0054
 Inteq ----- 0017
 JBL ----- 0054
 JCB ----- 0000
 JVC ----- 0053
 KEC ----- 0180
 KTV ----- 0180,0030
 Kenwood ----- 0030,0019
 Konka ----- 0707,0632,0628,0638,0703
 LG ----- 0056
 LXI ----- 0154,0047,0054,0156,0178
 Logik ----- 0016
 Luxman ----- 0056
 MGA ----- 0150,0019,0030,0178
 MTC ----- 0060,0030,0019,0056
 Magnavox ----- 0054,0030,0179,1254
 Majestic ----- 0016
 Marantz ----- 0054,0030
 Matsushita ----- 0250
 Megatron ----- 0145,0178
 Memorex 0179,0463,0178,0016,0056,0150,0154
 ,0250
 Midland ----- 0017,0047,0051
 Mitsubishi ----- 0150,0178,0019,0093
 Motorola ----- 0093
 Multitech ----- 0180
 NAD ----- 0156,0166,0178
 NEC ----- 0030,0019,0056

NTC ----- 0092
 Nikko ----- 0178,0030,0092
 Onwa ----- 0180
 Optimus ----- 0250,0166,0154
 Optonica ----- 0093
 Orion ----- 0463,0179,0236
 Panasonic ----- 0051,0250
 Penney 0047,1347,0060,0030,0178,0051,0019
 ,0056,0156
 Philco ----- 0145,0019,0030,0054,0463
 Philips ----- 0054
 Pilot ----- 0019,0030
 Pioneer ----- 0166,0679
 Portland ----- 0019,0092
 Princeton ----- 0717
 Prism ----- 0051
 Proscan ----- 0047
 Proton ----- 0178
 Pulsar ----- 0017,0019
 Quasar ----- 0051,0250
 RCA 0047,1347,1147,0679,1247,0019,0051
 ,0090,0093,1047,1447
 RadioShack 0180,0030,0178,0154,0019,0047,0056
 Realistic 0180,0154,0030,0178,0019,0056
 Runco ----- 0017,0030
 SSS ----- 0019,0180
 Sampo ----- 0030
 Samsung ----- 0060,0019,0178,0030,0056
 Sansei ----- 0451
 Sansui ----- 0463
 Sanyo ----- 0154
 Scimitus ----- 0019
 Scotch ----- 0178
 Scott ----- 0236,0019,0178,0179,0180
 Sears 0154,0056,0156,0047,0054,0171,0178
 ,0179
 Semivox ----- 0180
 Semp ----- 0156
 Sharp ----- 0093,0688
 Shogun ----- 0019
 Signature ----- 0016
 Sony ----- 0000

TELEVISION

Soundesign ----- 0178,0179,0180
 Squareview ----- 0171
 Starlite ----- 0180
 Supreme ----- 0000
 Sylvania ----- 0054,0030
 Symphonic ----- 0171,0180
 TMK ----- 0056,0178
 TNCi ----- 0017
 Tandy ----- 0093
 Technics ----- 0051,0250
 TechnolAce ----- 0179
 Techwood ----- 0051,0056
 Teknika ----- 0016,0054,0179,0180,
 0019,0092,0056,0060,0150
 Telefunken ----- 0056
 Toshiba ----- 0156,0060,0154,1256
 VectorResearch ----- 0030Victor0053
 Vidikron ----- 0054
 Vidtech ----- 0019,0178
 Wards 0054,0178,0016,0019,0030,0056,0179
 WhiteWestinghouse ----- 0624,0623,0463
 Yamaha ----- 0019,0030
 Zenith ----- 017,0624,0016,0092,0463

VCR

Admiral ----- 0048,0209
 Adventura ----- 0000
 Aiko ----- 0278
 Aiwa ----- 0000,0037
 AmericaAction ----- 0278
 AmericanHigh ----- 0035
 Asha ----- 0240
 Audiovox ----- 0037
 Beaumark ----- 0240
 Bell&Howell ----- 0104
 Broksonic ----- 0121,0184,0002,0209,0479
 CCE ----- 0072,0278
 Calix ----- 0037
 Canon ----- 0035
 Carver ----- 0081
 Cinal ----- 0278
 Citizen ----- 0278,0037
 Colt ----- 0072
 Craig ----- 0037,0072,0047,0240
 CurtisMathes ----- 0035,0060,0162
 Cybernex ----- 0240
 Daewoo ----- 0278,0045
 Denon ----- 0042
 Dynatech ----- 0000
 Electrohome ----- 0037
 Electrophonic ----- 0037
 Emerex ----- 0032
 Emerson 0184,0002,0209,0278,0121,0479,
 0000,0037,0043
 Fisher ----- 0047,0104
 Fuji ----- 0033,0035
 Funai ----- 0000
 GE ----- 0035,0060,0048,0240
 Garrard ----- 0000
 GoVideo ----- 0432
 GoldStar ----- 0037,0038
 Gradiente ----- 0000
 HI-Q ----- 0047
 HarleyDavidson ----- 0000
 Harman/Kardon ----- 0038,0081
 Harwood ----- 0072
 Hitachi ----- 0042,0000
 HughesNetworkSystems ----- 0042
 JVC ----- 0067
 KEC ----- 0037,0278
 KLH ----- 0072
 Kenwood ----- 0067,0038
 Kodak ----- 0035,0037
 LXI ----- 0037
 Lloyd's ----- 0000
 Logik ----- 0072
 MEI ----- 0035
 MGA ----- 0043,0240
 MGNTechnology ----- 0240
 MTC ----- 0000,0240
 Magnasonic ----- 0278
 Magnavox 0035,0081,0563,0000,0039,0149
 Magnin ----- 0240
 Marantz ----- 0081,0035
 Marta ----- 0037
 Matsushita ----- 0035,0162
 Memorex ----- 0104,0047,0479,0000,0037,
 0048,0035,0240,1037,0039,0162,0209,1162,1262
 Minolta ----- 0042
 Mitsubishi ----- 0043,0048,0067
 Motorola ----- 0035,0048
 Multitech ----- 0000,0072
 NEC ----- 0038,0067,0104
 Nikko ----- 0037
 Noblex ----- 0240

Olympus ----- 0035
Optimus 0162,1062,1162,0048,1262,0037,1048
,0104,0432
Orion ----- 0479,0002,0184,0209
Panasonic 0035,0162,1162,1262,1362,0616,1062
Penney ----0035,0240,0037,0042,0038
Pentax ----- 0042
Philco -----0035,0209,0479
Phillips ----0081,0035,0618,1081,1181
Pilot -----0037
Pioneer -----0067
PolkAudio -----0081
Profitronic ----- 0240
Proscan ----- 0060
Protec ----- 0072
Pulsar ----- 0039
Quasar ----- 0035,0162,1162
RCA 0060,0149,0042,0035,0048,0240
RadioShack -----0000,1037
Radix -----0037
Randex -----0037
Realistic 0000,0104,0047,0048,0037,0035
ReplayTV -----0614,0616
Runco ----- 0039
STS ----- 0042
Samsung ----- 0045,0240
Sanky -----0039,0048
Sansui ----- 0479,0000,0067,0209
Sanyo ----- 0047,0104,0240
Scott ----- 0184,0121,0043,0045
Sears 0037,0042,0000,0035,0047,0104

Semp ----- 0045
Sharp ----- 0048
Shintom ----- 0072
Shogun ----- 0240
Singer ----- 0072
Sony 0033,0032,0000,0035,0636,1032
Sylvania ----- 0035,0081,0000,0043
Symphonic ----- 0000
TMK ----- 0240
Teac ----- 0000
Technics -----0035,0162
Teknika ----- 0000,0035,0037
Thomas ----- 0000
Tivo -----0618,0636
Toshiba -----0045,0043
Totevision ----- 0037,024
Unitech ----- 0240
Vector ----- 0045
VectorResearch -----0038
VideoConcepts ----- 0045
Videosonic ----- 0240
Wards 0035,0060,0000,0047,0240, 0042,
0048, 0072,0081, 0149
WhiteWe stinghouse----- 0072,0278,0209
XR-1000 -----0072,0000,0035
Yamaha ----- 0038
Zenith ----0039,0000,0033,0209,0479

DVD(DIGITAL VIDEO DISC) LAYERS / RECORDERS

Apex ----- 0672
Denon ----- 0490
Fisher ----- 0670
GE ----- 0522
Gradiente -----0651
Hitachi -----0573,0664
Hiteker ----- 0672
JVC -----0623,0558
Kenwood -----0682,0534
Konka -----0719,0711,0720,0721
Magnavox -----0503,0675
Marantz ----- 0539
Mitsubishi -----0521
Onkyo ----- 0503
Optimus -----0571
Oritron -----0651
Panasonic ----- 0490,0677,0632
Phillips -----0539,0503
Pioneer ----- 0571,0525,0632
Proscan ----- 0522
RCA ----- 0522,0571
Samsung ----- 0573
Sharp ----- 0630
Sony ----- 0533
Technics ----- 0490
ThetaDigital -----0571
Toshiba ----- 0503
Yamaha -----0490,0545

ESTIMADO CLIENTE DE SHARP

Gracias por haber adquirido este TV de proyección posterior de SHARP. Para garantizar su seguridad y muchos años de uso sin problemas de su producto, por favor lea cuidadosamente las precauciones de seguridad importantes antes de usar este producto.

IMPORTANTE:



Para facilitarle la gestión de la información en caso de pérdida o robo, escriba por favor el número de modelo de TV y el número de serie en el espacio suministrado. Los números están ubicados en la parte trasera de la TV.

Nº modelo:

Nº serie:

INFORMACIÓN IMPORTANTE

ADVERTENCIA: PARA REDUCIR EL RIESGO DE QUE SE PRODUZCA UNA DESCARGA ELÉCTRICA, NO EXPONGA ESTE PRODUCTO A LA LLUVIA NI A LA HUMEDAD.

	<p>PRECAUCIÓN RIESGO DE DESCARGA ELÉCTRICA. NO RETIRE LOS TORNILLOS, EXCEPTO LOS QUE SE ESPECIFICAN PARA TAREAS DE.</p>	
<p>PRECAUCIÓN: PARA REDUCIR EL PELIGRO DE DESCARGA ELÉCTRICA, NO RETIRE LA TAPA. EL PRODUCTO NO CONTIENE COMPONENTES QUE PUEDA REPARAR EL USUARIO, EXCEPTO LA LÁMPARA. SOLICITE EL SERVICIO DE REPARACIÓN A PERSONAL CUALIFICADO.</p>		



El signo del rayo con punta de flecha en el interior de un triángulo equilátero tiene la finalidad de avisar al usuario de la presencia de tensión peligrosa no aislada dentro de la caja del producto, que puede ser de suficiente magnitud como para constituir un riesgo de descarga eléctrica para las personas.



El signo de exclamación en el interior de un triángulo tiene la finalidad de avisar al usuario de la presencia de importantes instrucciones de operación y mantenimiento (servicio) en los documentos que acompañan al producto. acompañan al producto.

ADVERTENCIA: Las normas FCC establecen que cualquier cambio o modificación no autorizados en este equipo no aprobado expresamente por el fabricante podría anular la autorización del usuario para utilizarlo.

ATENCIÓN:

Este producto cumple las normas FCC cuando se utilizan conectores y cables apantallados para conectar la unidad a otro equipo. Para evitar interferencias electromagnéticas con aparatos eléctricos, como radios y televisores, utilice conectores y cables apantallados para las conexiones.

DECLARACIÓN DE CONFORMIDAD

TV DE PROYECCIÓN POSTERIOR DE SHARP, MODELO 56DR650

TV DE PROYECCIÓN POSTERIOR DE SHARP, MODELO 65DR650

Este dispositivo cumple el Apartado 15 de las Normas FCC. El funcionamiento está sujeto a las siguientes dos condiciones:

(1) Este dispositivo no debe causar interferencias perjudiciales y (2) este dispositivo debe aceptar cualquier interferencia recibida, incluidas aquellas que provoquen un funcionamiento no deseado.

PARTE RESPONSABLE:

SHARP ELECTRONICS CORPORATION

Sharp Plaza, Mahwah, New Jersey 07430-2135

TEL: 1-800-BE-SHARP

For Business Customers: URL <http://www.sharppusa.com>

INFORMATION:

Este equipo se ha probado y se ha demostrado que cumple los límites de un dispositivo digital de Clase B, de acuerdo con el Apartado 15 de la normativa FCC. Estos límites están diseñados para proporcionar una protección razonable contra las interferencias perjudiciales en una instalación residencial. Este equipo genera, utiliza y puede irradiar energía de radiofrecuencia y, si no se instala y utiliza de acuerdo a las instrucciones, puede causar interferencias perjudiciales a las comunicaciones de radio. Sin embargo, no existen garantías de que el equipo no provocará interferencias en una instalación particular. Si este equipo provoca interferencias perjudiciales a la recepción de radio o televisión, lo que puede determinarse encendiéndolo y apagándolo, es recomendable intentar corregir las interferencias mediante una o varias de las siguientes medidas::

- Reorientar o reubicar la antena receptora.
- Aumentar la separación entre el equipo y el receptor.
- Conectar el equipo a una toma de corriente que se encuentre en un circuito distinto de al que está conectado el receptor.
- Solicitar ayuda al proveedor o a un profesional de radio y TV con experiencia.

“Nota para el instalador del sistema CATV: este recordatorio pretende llamar la atención del instalador del sistema CATV en relación al Artículo 820-40 del Código Eléctrico Nacional (NEC) en el que se proporcionan instrucciones para realizar una conexión a tierra adecuada y, en particular, especifica que el cable de tierra se debe conectar al sistema de tierra del edificio tan cerca del punto de entrada del cable como sea posible.”

Este producto utiliza soldaduras de estaño y tiene una lámpara fluorescente que contiene una pequeña cantidad de mercurio. Los residuos de estos materiales pueden estar regulados por motivos medioambientales. Para obtener información sobre residuos o reciclaje, póngase en contacto con las autoridades locales o con Electronic Industries Alliance: www.eia.org

MARCAS COMERCIALES

•Fabricado con licencia de Dolby Laboratories. “Dolby” Pro Logic y el símbolo de doble D son marcas comerciales de Dolby Laboratories.

•Fabricado con licencia de BBE Sound, Inc.
Licencia de BBE Sound, Inc. bajo USP, 5510752 y 5736897. BBE y el símbolo de BBE son marcas registradas de BBE Sound, Inc.

•HDMI, el logotipo de HDMI y High-Definition Multimedia Interface son marcas comerciales o marcas registradas de HDMI

•DCDi[®] de Faroudja es una marca registrada de Genesis Microchip Inc.

•DLP[™] (Digital Light Processing) y DMD[™] (Digital Micromirror Device) son marcas registradas de Texas Instruments, Inc.
•Algunos chips de CI contenidos en este producto incluyen información confidencial y/o secretos comerciales que son propiedad de Texas Instruments. Por lo tanto, se prohíbe copiar, modificar, adaptar, traducir, distribuir, realizar ingeniería inversa, desmontar o descompilar la información contenida en estos chips.

INSTRUCCIONES DE SEGURIDAD IMPORTANTES

ATENCIÓN:lea todas estas instrucciones antes de utilizar el producto y guárdelas por si tuviera que consultarlas en otro momento.

Muchas de las funciones útiles funcionan gracias a la electricidad pero ésta también puede causar daños al producto y al usuario si se manipula de forma inadecuada. Este producto se ha diseñado y fabricado teniendo en cuenta la seguridad como prioridad máxima. No obstante, el uso inapropiado puede provocar descargas eléctricas e incendio. Para evitar daños potenciales, tenga en cuenta las siguientes instrucciones cuando instale, utilice y limpie el producto. Para garantizar la seguridad y prolongar la vida del Televisor de proyección posterior, lea atentamente las siguientes precauciones antes de utilizarlo.

- 1) Lea estas instrucciones.
- 2) Guarde estas instrucciones.
- 3) Tenga en cuenta todas las advertencias.
- 4) Siga todas las instrucciones.
- 5) No utilice este aparato cerca de lugares que contengan agua.
- 6) Limpie el aparato sólo con un paño seco.
- 7) No bloquee ninguna abertura de ventilación. Realice la instalación siguiendo las instrucciones del fabricante.
- 8) No coloque el aparato cerca de fuentes de calor, como por ejemplo radiadores, hornillos u otros aparatos (incluidos amplificadores) que produzcan calor.
- 9) DNo ignore el objetivo de seguridad del enchufe con toma de tierra o polarizado. Un enchufe polarizado tiene dos clavijas, una más ancha que la otra. Un enchufe con toma de tierra tiene dos clavijas y una tercera clavija de toma de tierra. La clavija ancha o la tercera clavija se incluyen por su seguridad. Si el enchufe suministrado no encaja en la toma de corriente, consulte con un electricista para cambiar la toma de corriente obsoleta.
- 10) Proteja el cable de corriente para que no se pise ni se pellizque, especialmente en los enchufes, las tomas de corriente y el punto donde salen del aparato.
- 11) Utilice únicamente accesorios especificados por el fabricante.
- 12) Utilice el aparato sólo con un carro, base, trípode, soporte o mesa especificado por el fabricante o vendido conjuntamente con dicho aparato. Si utiliza un carro, preste atención cuando lo desplace para evitar daños por caída.
- 13) Desconecte el aparato durante las tormentas eléctricas o cuando no se utilice durante un período prolongado de tiempo.
- 14) Remita todas las reparaciones al personal de servicio técnico cualificado. Será necesario acudir al servicio técnico siempre que se dañe de forma alguna el aparato, por ejemplo cuando la fuente de alimentación o el enchufe estén dañados, cuando se haya derramado líquido o se hayan caído objetos dentro del aparato, cuando éste se haya expuesto a la lluvia o la humedad, no funcione normalmente o se haya dejado caer.
- 15) Fuentes de alimentación. Sólo se debe aplicar al producto el tipo de alimentación indicado en el etiquetado. Si no está seguro del tipo de alimentación de su domicilio, póngase en contacto con su distribuidor o con la compañía eléctrica local. Para productos diseñados para que funcionen con batería u otras fuentes de alimentación, consulte las instrucciones de funcionamiento.
- 16) Sobrecarga. No sobrecargue las tomas de corriente ni los alargadores ya que se puede provocar un incendio o descargas eléctricas.
- 17) Inserción de objetos y líquidos. Nunca coloque objetos de ningún tipo en este producto de forma que obturen sus aberturas, ya que pueden entrar en contacto con componentes de alto voltaje o cortocircuitar éstos, lo que podría dar lugar a un incendio o descargas eléctricas. Nunca derrame líquidos de ningún tipo sobre el producto.
- 18) Daños que requieren servicio técnico. Desenchufe el producto de la toma de corriente y comunique todas las reparaciones al personal de servicio técnico cualificado cuando se den las siguientes condiciones:
 - a) El cable de AC está dañado,
 - b) Se ha derramado líquido o han caído objetos sobre el producto,
 - c) El producto se ha expuesto a la lluvia o al agua,
 - d) El producto no funciona con normalidad y, sin embargo, se han seguido las instrucciones de funcionamiento.
Ajuste sólo los controles descritos en las instrucciones de funcionamiento; el ajuste inadecuado de otros controles puede provocar daños y obligar al personal técnico cualificado a realizar un trabajo exhaustivo para que el producto vuelva a funcionar con normalidad,
 - e) El producto se ha dejado caer o ha sufrido daños de alguna manera
 - f) El producto muestra un cambio claro de rendimiento, lo que indica la necesidad de tareas de mantenimiento.
- 19) Reemplazar piezas. Cuando sea necesario reemplazar piezas, asegúrese de que el técnico ha empleado piezas de repuesto especificadas por el fabricante o que tienen las mismas características que las originales. Las sustituciones no autorizadas pueden provocar un incendio, descargas eléctricas o constituir otros riesgos.
- 20) Comprobación de seguridad. Después de realizar cualquier tarea de mantenimiento o reparación de este producto, pida al técnico que realice comprobaciones de seguridad para determinar si el producto funciona perfectamente.



INSTRUCCIONES DE SEGURIDAD IMPORTANTES

- Agua y humedad — No utilice este producto cerca del agua como, por ejemplo, una bañera, palangana, fregadero de cocina o lavadora; en un sótano húmedo; cerca de una piscina o un lugar similar.
- Selección de la ubicación. seleccione un lugar en el que no incida directamente la luz del y tenga una ventilación adecuada.
- Ventilación. Los conductos de ventilación y otras aberturas de la carcasa están diseñados para proporcionar una ventilación adecuada. No tape ni bloquee dichos conductos de ventilación ni aberturas ya que una ventilación insuficiente podría sobrecalentar y/o acortar la vida del producto. No coloque el producto sobre una cama, sofá, alfombra o superficie de similares características, ya que podrían obturar las aberturas de ventilación. Este producto no está diseñado para instalaciones integradas; no lo coloque en un lugar cerrado, como una estantería o bastidor, a menos que se proporcione la ventilación adecuada o que se cumplan las instrucciones del fabricante.
- Calor. El producto no debe situarse cerca de ninguna fuente de calor, como por ejemplo, radiadores, suministros de calor, hornillos u otros aparatos (incluidos amplificadores) que produzcan calor.
- Iluminación. Si desea proporcionar protección adicional a este equipo de televisión durante una tormenta o cuando no se utilice durante un prolongado periodo de tiempo, desenchúfelo de la toma de corriente y desconecte la antena. De esta forma evitará que las subidas de corriente lo dañen.

- Líneas de alta tensión. Un sistema de antena exterior no se debe colocar junto a líneas eléctricas elevadas u otros circuitos de potencia o de iluminación eléctricos, ni en lugares donde puedan caer sobre tales líneas o circuitos eléctricos. Cuando instale un sistema de antena exterior, extreme las precauciones para no tocar las líneas o circuitos eléctricos, pues las consecuencias pueden ser fatales.

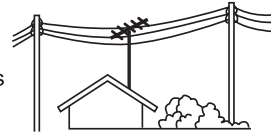

- Conexión a tierra de la antena exterior. Si conecta una antena exterior al equipo de televisión, asegúrese de que el sistema de la misma tiene conexión a tierra para proporcionar protección contra subidas de tensión y cargas estáticas. El Artículo 810 del Código Eléctrico Nacional ANSI/NFPA 70, proporciona información sobre las siguientes cuestiones: conexión adecuada a toma de tierra de postes y estructuras de soporte, conexión de toma de tierra del cable de entrada a una unidad de descarga de antena, tamaño de los conductores de toma de tierra, ubicación de la unidad de descarga de antena, conexión a electrodos de toma de tierra y requisitos para el electrodo de toma de tierra.

EJEMPLO DE CONEXIÓN DE LA ANTENA A TIERRA SEGÚN EL CÓDIGO ELÉCTRICO NACIONAL, ANSI/NFPA 70

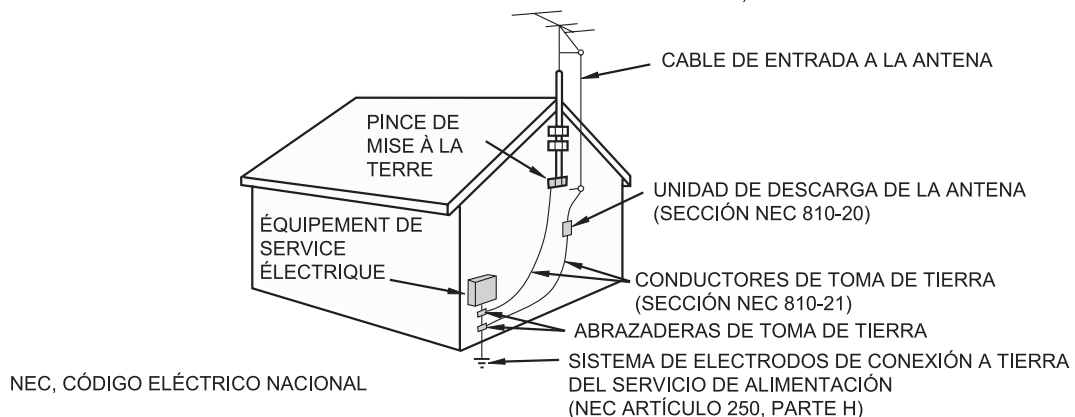

- Para evitar incendios o descargas eléctricas, no exponga el monitor al agua, salpicaduras, lluvia o humedad. No coloque recipientes que contengan líquido (como jarrones o floreros) en el producto.
- Para evitar incendios y descargas eléctricas, no coloque el cable de alimentación de CA bajo el televisor ni otros objetos pesados.

Sección de control lateral

Alimentación

"Encienda" el televisor presionando el botón de encendido una vez. "Apáguelo" presionando el botón de encendido dos veces; la primera vez que presione el botón aparecerá un mensaje en la pantalla advirtiéndole de que la segunda vez que presione el botón el televisor se apagará.

Entrada

Si presiona repetidamente este botón recorrerá las fuentes de entrada secuencialmente.

Una vez seleccionadas todas las entradas, regresará a la entrada por la que comenzó.

Menú y Salir

Al presionar este botón se activa el menú OSD que muestra el menú principal. Si vuelve a presionar el botón, el menú OSD se cerrará.

Aceptar

AL presionar este botón se activa el menú OSD y se muestra el menú principal.

Canal +/- y Ajuste ▲/▼

Sube (+) o baja (-) los canales de TV. Mientras el menú OSD esté activo, funcionan como botones de ajuste para seleccionar opciones de dicho menú.

Volumen +/- y Ajuste ◀/▶

Sube (+) o baja (-) el volumen del altavoz. Mientras el menú OSD esté activo, funcionan como botones de ajuste para cambiar las opciones de dicho menú.

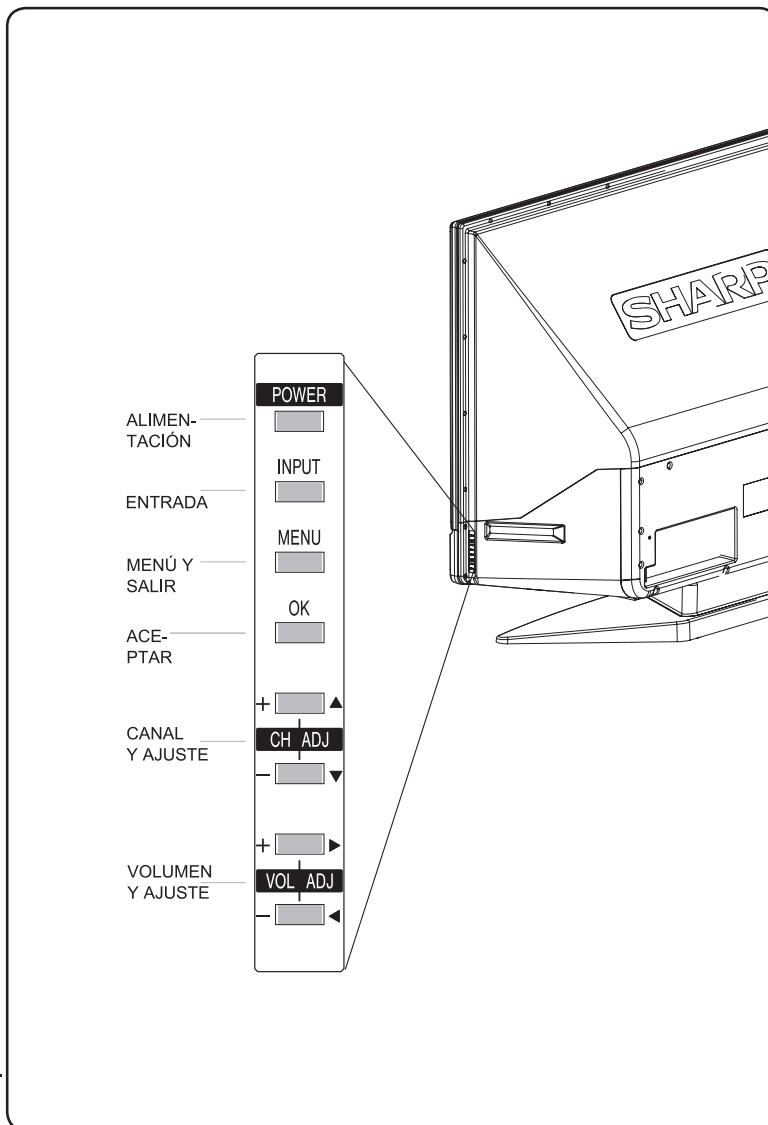

LED de estado

Indicador del panel frontal

LED de la lámpara

Muestra el estado de la lámpara de la unidad RPTV.

LED de encendido

Se ilumina en color verde cuando está encendido.

Sensor del mando a distancia

Apunte con el mando a distancia aquí ya que es la ventana a través de la cual pasan todas las señales del mando a distancia para alcanzar el sensor remoto.

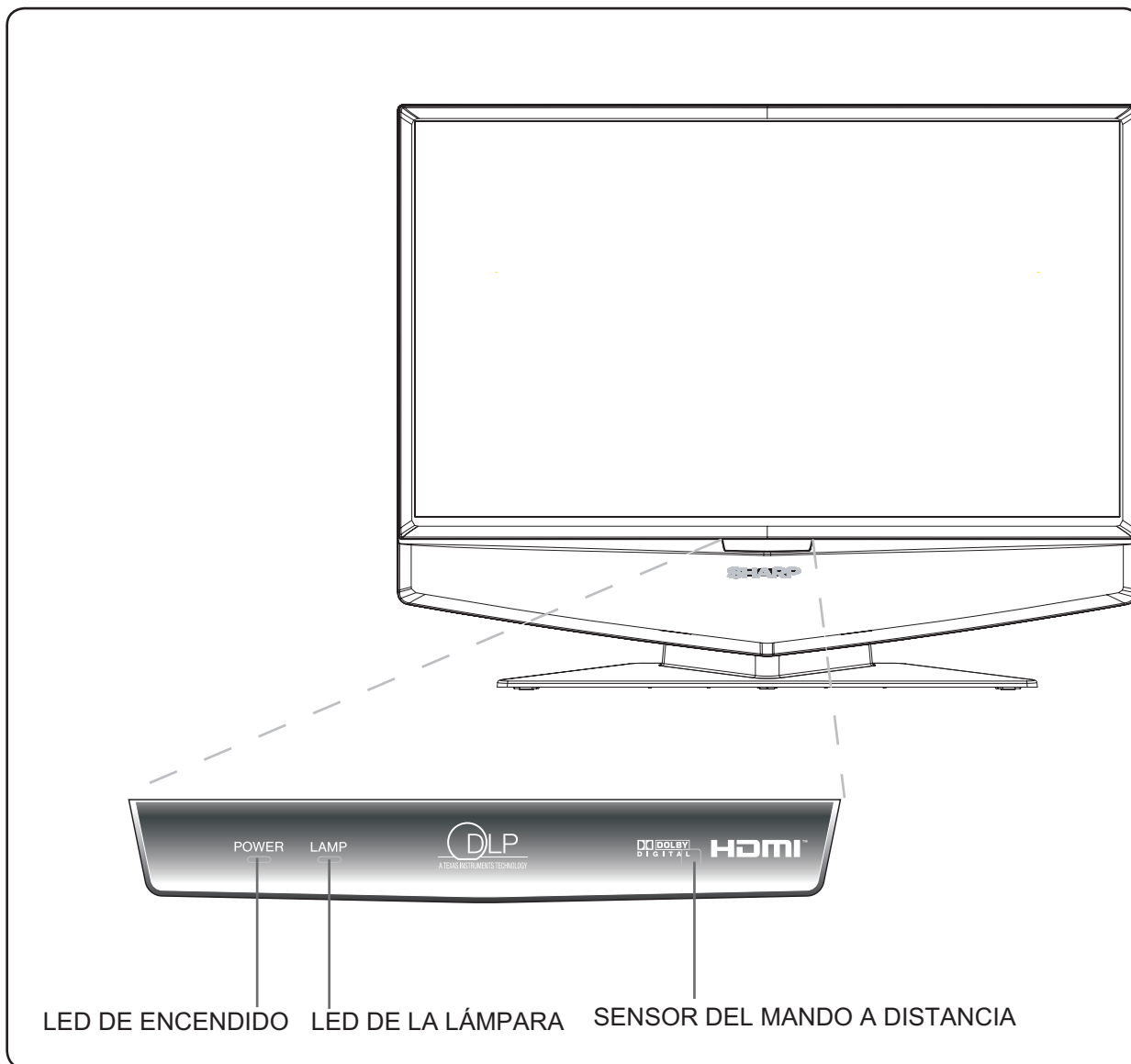

Funciones de los botones del mando a distancia

El mando a distancia es un dispositivo remoto global que se puede utilizar para controlar hasta ocho componentes diferentes. Para facilitar el en condiciones de poca luminosidad, el mando a distancia tiene una luz de fondo que ilumina todos los botones cuando se presiona uno de ellos. La luz se apaga automáticamente al cabo de unos segundos después de presionar un botón. Las funciones de los botones del mando a distancia se explican a continuación.

LED remoto

Parpadea cuando el mando a distancia se está programando o enviando una orden al televisor.

CONFIGURAR

Inicia las secuencias de programación.

ENCENDIDO

Enciende y "apaga" el "aparato" RPTV u otro componente seleccionado. Botones de componentes

Puede programar estos botones para seleccionar los componentes que desea que controle el mando a distancia.

TV	Está preprogramado para utilizar el aparato RPTV.
DVD	Selecciona un reproductor de DVD programado.
VCR	Selecciona un equipo VCR programado.
CBL	Selecciona un decodificador de cable.
SAT	Selecciona un receptor de satélite programado.
AMP	Selecciona un receptor programado.
CD	Selecciona un reproductor de CD programado.
AUX	Selecciona un componente programado.

*Consulte la página 36 para configurar un código de fabricante favorable.

Teclado numérico

Utilice estos botones para seleccionar un canal de TV directamente por el número de canal o para insertar la contraseña.

Ejemplos:

Para el canal 20, presione el botón '2' y, a continuación, el botón '0' antes de que transcurran 5 segundos.

Para el canal 7, presione el botón '7' y espere unos cinco (5) segundos; si no desea esperar, presione los botones '0' y '7'.

ACEPTAR (ENTER) ".": permite seleccionar un subcanal

ANTERIOR (FLASHBACK): permite volver al canal anterior.

SILENCIO (MUTE): permite desactivar el sonido.

APAGADO AUTOMÁTICO (SLEEP): permite mostrar el tiempo que queda para al apagado automático.

ENTRADA (INPUT): permite seleccionar el tipo de señal: DTV, AV1, AV2, AV3, COMP1, COMP2, RGB, HDMI, TV.

VOL: permite controlar el volumen presionando los botones "+" o "-". Canal (CH): permite seleccionar un canal presionando los botones "+" o "-".

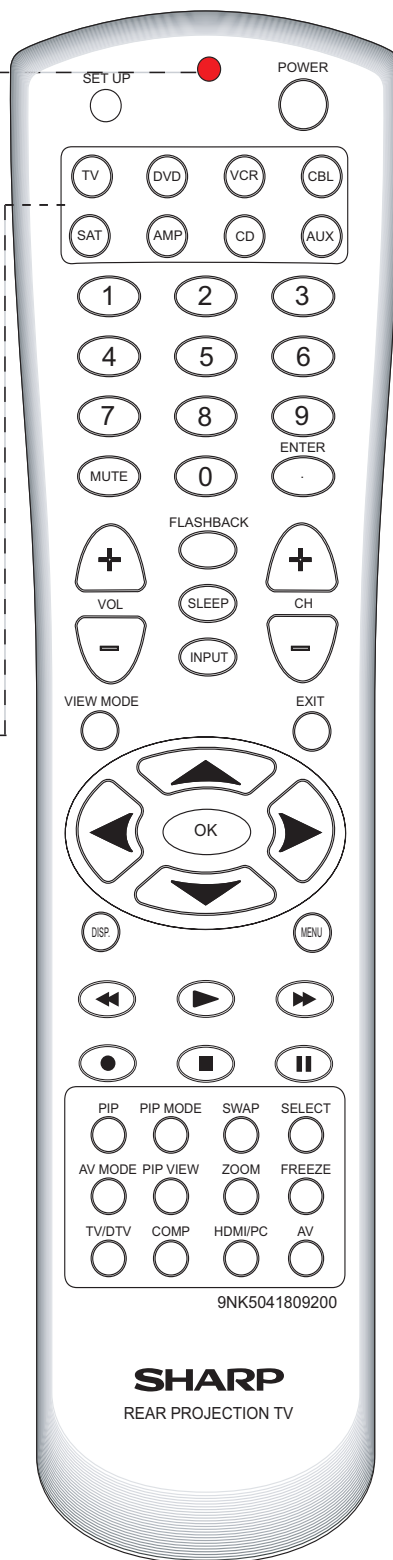

Funciones de los botones del mando a distancia

MODO DE VISTA (VIEW MODE) PARA VÍDEO

- ALARGAR 16:9
- BARRA LATERAL 4:3
- ALARGAR S 16:10
- ZOOM

MODO DE VISTA (VIEW MODE) PARA PC

- NORMAL
- ALARGAR 16:9
- PUNTO POR PUNTO

SALIR (EXIT)

Permite salir de del menú OSD de los componentes o de los menús en general.

▲, ▼, ◀, ▶

Utilice estos botones para recorrer los menús OSD.

ACEPTAR (OK)

Permite confirmar una acción.

INFORMACIÓN (DISP)

Muestra el estado actual de la fuente de vídeo, audio (y el número de canal cuando está establecido el modo TV), en la pantalla de la unidad RPTV.

MENÚ (MENU)

Permite activar el menú OSD y salir de él directamente.

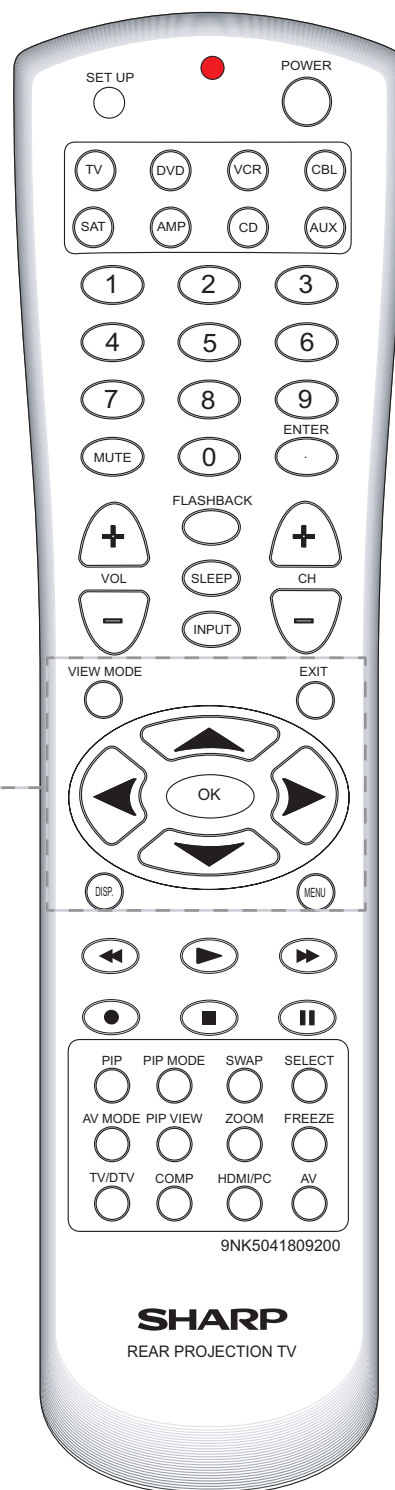

Funciones de los botones del mando a distancia

PIP

Permite activar y desactivar los modos PIP (Picture In Picture) o POP (Picture On Picture).

SELECCIONAR (SELECT)

Permite seleccionar la ventana principal o secundaria para activarla.

MODO PIP (PIP MODE)

Permite seleccionar el estilo del modo PIP.

INTERCAMBIAR (SWAP)

Permite intercambiar la imagen principal y secundaria cuando el modo PIP o POP está activado. Permite cambiar la fuente de vídeo para la imagen secundaria PIP o POP.

Cuando se elige con uno de los botones de componentes, indica al equipo VCR, CD o DVD que pause la reproducción.

ZOOM

Permite cambiar el tamaño de zoom para ampliar la pantalla a un tamaño 2X y 4X.

CONGELAR (FREEZE)

Permite congelar la imagen. Tenga en cuenta que el contenido de audio y vídeo seguirán cambiando y cuando presione este botón de nuevo para desactivar el modo Congelar, la imagen no volverá al mismo punto en el que se encontraba en el momento de congelarla.

TV/DTV

Permite seleccionar TV como fuente de vídeo.

COMP

Permite seleccionar alternativamente la entrada de componentes COMP1 o COMP2.

HDMI / PC

Permite seleccionar alternativamente la entrada HDMI o PC.

AV

Alternativamente, seleccione las entradas AV1, AV2 o AV3.

MODO AV (AV MODE)

Configuración AV predefinida: ESTÁNDAR, PELÍCULA, JUEGOS, TV-USUARIO, DINÁMICO (FIJO), DINÁMICO.

VISTA PIP (PIP VIEW)

Permite cambiar el modo de vista de la ventana secundaria a 16:9 o 4:3



CHER CLIENT SHARP

Nous vous remercions de votre achat de ce téléviseur à rétro-projection Sharp. Pour en assurer la sécurité et le bon fonctionnement pendant de longues années, veuillez lire attentivement les consignes de sécurité importantes avant l'utilisation.

IMPORTANT:



Pour faciliter la déclaration de perte ou de vol, veuillez noter les numéros de modèle et de série dans l'espace prévu à cet effet. Vous trouverez ces numéros au dos du téléviseur.

No de modèle.

No de série.

INFORMATIONS IMPORTANTES

AVERTISSEMENT : POUR RÉDUIRE LES RISQUES D'INCENDIE ET D'ÉLECTROCUTION, NE PAS EXPOSER CET APPAREIL À LA PLUIE OU À L'HUMIDITÉ.

	ATTENTION RISQUE D'ÉLECTROCUTION. NE PAS ENLEVER LES VIS AUTRES QUE LES VIS DE SERVICE UTILISATEUR SPÉCIFIÉES	
ATTENTION: AFIN D'ÉVITER LES RISQUES D'ÉLECTROCUTION, NE PAS RETIRER LE CAPOT SUPÉRIEUR. L'APPAREIL NE CONTIENT AUCUNE PIÈCE QUE L'UTILISATEUR PUISSE REMPLACER, À L'EXCLUSION DE LA LAMPE. CONFIER TOUTE RÉPARATION À UN PERSONNEL QUALIFIÉ.		



Le symbole de l'éclair inscrit dans un triangle équilatéral est un avertissement à l'attention de l'utilisateur sur la présence, à l'intérieur du produit, de pièces non isolées soumises à une "très haute tension" pouvant provoquer une électrocution.



Le symbole du point d'exclamation, inscrit dans un triangle équilatéral, a pour objet d'appeler l'attention de l'utilisateur sur la présence, dans la documentation accompagnant le produit, d'importantes instructions concernant son mode opératoire et son entretien (réparation).

MISE EN GARDE : La réglementation de la FCC indique que tout changement ou toute modification de cet équipement non expressément approuvé par le fabricant est de nature à priver l'utilisateur de l'autorité nécessaire pour mettre cet. .équipement en oeuvre.

ATTENTION:

Ce produit est conforme à la réglementation de la FCC lorsque des connecteurs et des câbles blindés sont utilisés pour le connecter aux autres équipements. Afin de prévenir toute interférence avec d'autres appareils électriques tels que radios et téléviseurs, utilisez des connecteurs et des câbles blindés pour les connexions.

DECLARATION OF CONFORMITY

TÉLÉVISEUR À RÉTROPROJECTION SHARP, MODÈLE 56DR650

TÉLÉVISEUR À RÉTROPROJECTION SHARP, MODÈLE 56DR650

Ce périphérique est conforme à la partie 15 des Règles de la FCC. Sa mise en oeuvre est soumise aux deux conditions suivantes :

(1) Ce périphérique ne doit pas causer de brouillage préjudiciable et (2) ce périphérique doit être capable d'accepter tout brouillage reçu, y compris le brouillage susceptible de causer un dysfonctionnement.

PARTIE RESPONSABLE:

SHARP ELECTRONICS CORPORATION

Sharp Plaza, Mahwah, New Jersey 07430-2135

TEL : 1-800-BE-SHARP

For Business Customers: URL <http://www.sharppusa.com>

INFORMATIONS:

Cet équipement a été testé et trouvé satisfaisant aux limites des périphériques numériques de Classe B conformément au Règle 15 des règles de la FCC. Ces limites ont été définies pour garantir une protection raisonnable contre le brouillage préjudiciable dans le cadre d'une installation domestique. Cet équipement génère, utilise et peut irradier une énergie de fréquence radio et, s'il n'est pas utilisé conformément aux instructions, il risque de causer un brouillage préjudiciable aux radiocommunications. Cependant, aucune garantie n'est donnée qu'il ne causera pas de brouillage dans une installation en particulier. Si cet équipement provoque un brouillage préjudiciable à la réception de la radio ou de la télévision, ce qui peut être déterminé en éteignant puis en rallumant l'appareil, l'utilisateur est encouragé à tenter de corriger le brouillage en prenant l'une ou plusieurs des mesures suivantes :

- Réorienter ou déplacer l'antenne de réception.
- Augmenter la distance séparant l'équipement du récepteur.
- Brancher l'équipement sur une prise électrique relevant d'un circuit différent de celui sur lequel le récepteur est branché.
- Demander de l'aide au revendeur ou à un technicien radio / TV expérimenté..

"Note à l'attention de l'installateur du système de télévision par câble : L'attention des installateurs de systèmes de télévision par câble est attirée sur les dispositions de l'Article 820-40 du Code national de l'électricité (NEC), qui donne des consignes quant à la mise à la terre correcte et, en particulier, spécifie que la mise à la terre des câbles doit être connectée au système de mise à la terre du bâtiment, aussi près que possible du point d'entrée des câbles."

Ce produit utilise une soudure au plomb et à l'étain, et une lampe fluorescente contenant du mercure en petite quantité. Il se peut que la mise au rebut de ces matières fasse l'objet de mesures réglementaires visant à protéger l'environnement. Pour les informations concernant la mise au rebut et le recyclage, veuillez prendre contact avec vos autorités locales ou avec l'Alliance des industries de l'électronique (Electronic Industries Alliance) : www.eia.org

MARQUES

•Fabriqué sous licence de Dolby Laboratories. Dolby et le symbole Double-D sont des marques de commerce de Dolby Laboratories.

•Fabriqué sous licence de BBE Sound, Inc.
Licence accordée par BBE Sound, Inc. sous les numéros USP, 5510752 et 5736897. BBE et le symbole BBE sont des marques déposées de BBE Sound, Inc.

•HDMI, le logo HDMI et High-Definition Multimedia Interface sont des marques de commerce ou des marques déposées de HDMI Licensing LLC.

• DCDi ® par Faroudja est une marque déposée de Genesis Microchip Inc.

•DLP™ (Digital Light Processing) et DMD™ (Digital Micromirror Device) sont des marques de commerce de Texas Instruments, Inc.
•Certains circuits intégrés utilisés dans ce produit font l'objet de secrets de fabrication appartenant à Texas Instruments. Il est donc interdit de copier, de modifier, de traduire, de distribuer, d'étudier la conception, de démonter ou de décompiler leur contenu.

IMPORTANTES INSTRUCTIONS DE SÉCURITÉ

ATTENTION: Veuillez lire l'ensemble de ces instructions avant d'utiliser ce produit et conserver ces instructions de façon à pouvoir vous y reporter ultérieurement.

L'électricité est utilisée pour de nombreuses applications usuelles, mais, en cas de mauvaise manipulation, elle risque d'entraîner des accidents matériels et physiques. Ce produit a été conçu et fabriqué en accordant le plus grande priorité à la sécurité. Cependant, toute mauvaise utilisation risque de présenter des risques d'électrocution ou d'incendie. Afin de prévenir tout danger potentiel, veuillez respecter les instructions qui suivent lorsque vous installez, utilisez et nettoyez le produit. Afin de garantir votre sécurité et de prolonger la durée de vie de votre Téléviseur à rétroprojection, veuillez lire attentivement les précautions qui suivent avant d'utiliser le produit.

- 1) Veuillez lire ces instructions.
- 2) Conservez ces instructions.
- 3) Tenez compte de tous les avertissements.
- 4) Suivez toutes les instructions.
- 5) Ne pas utiliser cet appareil à proximité de l'eau.
- 6) Pour le nettoyage, utilisez exclusivement un chiffon sec.
- 7) Ne bloquez aucun des orifices de ventilation. Installez cet équipement en respectant les instructions du fabricant.
- 8) Ne pas installer près de sources de chaleur telles que radiateurs, bouches à air chaud, fours, ou autres appareils (y compris les amplificateurs) qui produisent de la chaleur.
- 9) Ne vous privez pas de la sécurité apportée par la fiche polarisée ou la fiche avec prise de terre. Une fiche polarisée possède deux plots, dont l'un est plus large que l'autre. Une fiche avec prise de terre possède deux plots et un troisième connecteur de mise à la terre. Le plot plus large et le troisième connecteur sont là pour votre sécurité. Si la fiche fournie n'entre pas dans votre prise, veuillez demander conseil à un électricien pour le remplacement de la prise obsolète.
- 10) Protégez le cordon d'alimentation contre tous risques de piétinement ou de pincement, en particulier au niveau des prises électriques et des prises multiples, et au niveau du point de sortie de l'appareil.
- 11) Utilisez exclusivement les accessoires spécifiés par le fabricant.
- 12) Utilisez l'appareil exclusivement avec le chariot, le stand, le trépied, le support ou la table spécifié(e) par le fabricant ou vendu avec l'appareil. Lorsqu'un chariot est utilisé, faites attention lorsque vous déplacez l'ensemble chariot / appareil afin d'éviter tout accident causé par un basculement de l'appareil.
- 13) Débranchez cet appareil pendant les orages avec éclairs ou lorsque l'appareil doit rester inutilisé pendant une longue période de temps.
- 14) Pour toute réparation, veuillez faire appel à un technicien de réparation qualifié. Une réparation est nécessaire lorsque l'appareil a été endommagé d'une façon ou une autre, par exemple lorsque le cordon d'alimentation ou la fiche électrique a été endommagé, lorsque du liquide a été renversé ou des objets sont tombés dans l'appareil, lorsque l'appareil a été exposé à la pluie ou à l'humidité, lorsqu'il ne fonctionne pas normalement ou lorsqu'il est tombé. 
- 15) Sources d'alimentation - Ce produit doit être utilisé exclusivement avec le type d'alimentation indiqué sur l'étiquette de repérage. Si vous n'êtes pas sûr du type d'alimentation disponible chez vous, veuillez demander conseil à votre revendeur ou votre compagnie locale d'électricité. Pour les produits qui sont conçus pour être alimentés par une batterie ou d'autres sources, veuillez vous reporter aux instructions d'utilisation.
- 16) Surcharge - Ne surchargez pas les prises murales, les rallonges ou les prises multiples intégrées, car cela risquerait de provoquer un incendie ou une électrocution.
- 17) Entrée d'objets ou de liquides - Ne jamais insérer d'objet d'aucune sorte dans les orifices du produit, car ils risquent de toucher des endroits avec des tensions dangereuses ou de provoquer un court-circuit pouvant provoquer un incendie ou une électrocution. Ne jamais renverser de liquide d'aucune sorte sur le produit.
- 18) Dommages nécessitant une intervention - Débranchez ce produit de la prise murale et demandez l'aide d'un technicien de réparation qualifié dans tous les cas suivants :
 - a) Lorsque la fiche ou le cordon d'alimentation a été endommagé,
 - b) Si du liquide a coulé ou si des objets sont tombés dans le produit,
 - c) Si le produit a été exposé à la pluie ou à l'eau,
 - d) Si le produit ne fonctionne pas normalement alors que vous suivez les instructions d'utilisation.

Réglez uniquement les contrôles qui sont couverts par les instructions d'utilisation, car tout réglage incorrect des autres contrôles risque de provoquer des dommages et de nécessiter un travail important de la part d'un technicien qualifié pour pouvoir remettre ce produit en état de marche,
 - e) Si le produit est tombé ou s'il a subi un dommage quelconque, et
 - f) Si vous constatez un changement sensible des performances du produit - ce qui indique qu'il a besoin d'être réparé.
- 19) Pièces de rechange - Lorsqu'il est nécessaire de remplacer des pièces, assurez-vous que le technicien de maintenance utilise bien les pièces de rechange spécifiées par le fabricant et que ces pièces possèdent bien les mêmes caractéristiques que les pièces d'origine. Tout remplacement non autorisé risque de provoquer un incendie, une électrocution, ou d'autres risques.
- 20) Contrôle de sécurité — Après toute opération de maintenance ou de réparation sur ce produit, demandez au technicien de maintenance de procéder aux contrôles de sécurité pour vous assurer que le produit est en bon état de marche.

IMPORTANTES INSTRUCTIONS DE SÉCURITÉ

• Eau et humidité - Ne pas utiliser ce produit près de l'eau, par exemple près d'une baignoire, d'un lavabo, d'un évier de cuisine ou d'un bac à linge, dans une cave humide ou près d'une piscine et autres endroits similaires.

• Sélection de l'emplacement - Sélectionner un endroit non exposé directement au soleil et bien ventilé.

• Ventilation - Les orifices et autres ouvertures pratiqués dans le cabinet sont prévus pour la ventilation. Ne bloquez pas, n'obstruez pas ces ouvertures et orifices car une ventilation insuffisante risque de causer une surchauffe et/ou de raccourcir la durée de vie du produit. Ne placez pas le produit sur un lit, un canapé, un tapis ou tout autre surface similaire qui risquerait de bloquer les orifices de ventilation. Ce produit n'a pas été conçu pour être installé de façon encastrée, ne l'installez pas dans un endroit fermé, comme par exemple dans une bibliothèque ou une étagère, à moins d'avoir prévu une ventilation suffisante ou de suivre les instructions du fabricant.

• Chaleur - Ce produit doit être éloigné des sources de chaleur telles que radiateurs, bouches à air chaud, fours et autres produits (y compris les amplificateurs) qui produisent de la chaleur.

• Foudre - Pour une meilleure protection de ce téléviseur pendant les orages magnétiques, ou lorsque le téléviseur doit rester sans surveillance et inutilisé pendant une longue période de temps, débranchez-le de la prise du secteur et débranchez l'antenne. Cela permettra d'éviter les dommages causés à l'équipement par la foudre ou les surtensions du secteur.

• Lignes électriques - Le système d'antenne extérieur ne doit pas être situé sous des lignes électriques ou d'autres circuits d'alimentation ou d'éclairage électrique, ou dans un endroit où il risque de tomber sur ces circuits ou ces lignes électriques. Lors de l'installation d'un système d'antenne externe, un soin extrême doit être apporté pour éviter de toucher tout circuit ou toute ligne d'alimentation électrique, qui présente un danger mortel si vous le/la touchez.



• Mise à la terre de l'antenne externe - Si vous connectez une antenne externe sur le téléviseur, assurez-vous que le système d'antenne est bien relié à la terre afin de vous protéger contre les surtensions et les décharges d'électricité statique.

L'article 810 du Code national de l'électricité, ANSI/NFPA No. 70-1984, donne des informations sur la mise en conformité avec une mise à la terre adéquate du mât et de la structure de soutien, la mise à la terre du câble conducteur d'entrée à une unité de décharge d'antenne, la taille des connecteurs de mise à la terre, l'emplacement de l'unité de décharge d'antenne, la connexion aux électrodes de mises à la terre et sur les exigences concernant l'électrode de mise à la terre.

EXEMPLE DE MISE À LA TERRE D'UNE ANTENNE
CONFORME AUX DISPOSITIONS DU CODE NATIONAL
DE L'ÉLECTRICITÉ, ANSI/NFPA 70

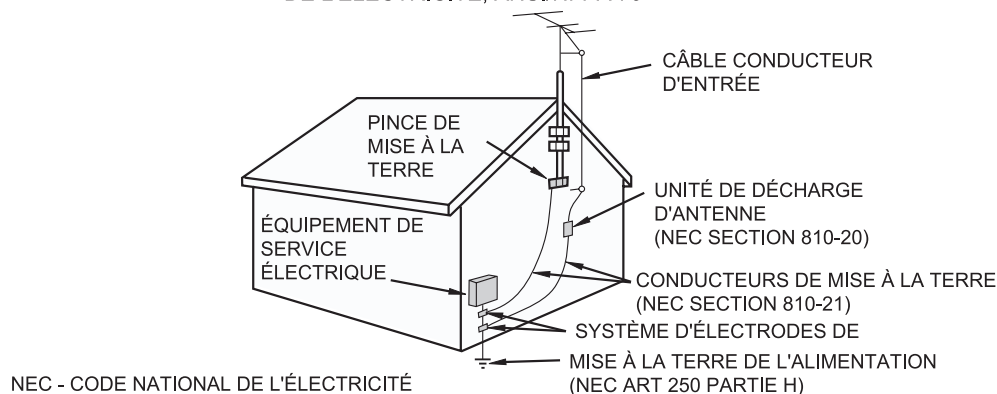

• Afin de prévenir les risques d'incendie ou d'électrocution, ne pas exposer ce produit aux écoulements ou éclaboussures. Aucun objet contenant un liquide, comme par exemple un vase, ne doit être placé sur le produit.

• Afin de prévenir les risques d'incendie ou d'électrocution, ne pas placer le cordon d'alimentation sous le téléviseur ou d'autres objets lourds

Contrôles latéraux

Alimentation

Allumez le téléviseur en appuyant une fois sur le bouton alimentation. Pour éteindre le téléviseur, appuyez deux fois sur le bouton d'alimentation ; la première fois que vous appuyez sur le bouton, un message s'affiche à l'écran pour vous indiquer que si vous appuyez une seconde fois, le téléviseur sera éteint.

Entrée

Appuyez plusieurs fois sur ce bouton pour faire défiler les entrées l'une après l'autre. Une fois que vous avez sélectionné toutes les entrées, vous retournez sur l'entrée à partir de laquelle vous avez commencé

Menu et Quitter

Appuyez sur ce bouton pour activer l'OSD (On Screen Display) et afficher le Menu Principal. Appuyez sur ce bouton de nouveau pour quitter (fermer) l'OSD.

OK

Appuyez sur ce bouton pour activer l'OSD et afficher le Menu Principal.

Chaîne +/- et Réglage ▲/▼

Permet d'aller sur la chaîne de télévision suivante (+) ou précédente (-). Lorsque l'OSD est actif, ces boutons servent de boutons de réglage pour sélectionner les options de l'OSD.

Volume +/- et Réglage ◀/▶

Pour augmenter (+) ou réduire (-) le volume des haut-parleurs. Lorsque l'OSD est actif, ces boutons font office de boutons de réglage pour régler les options de l'OSD.

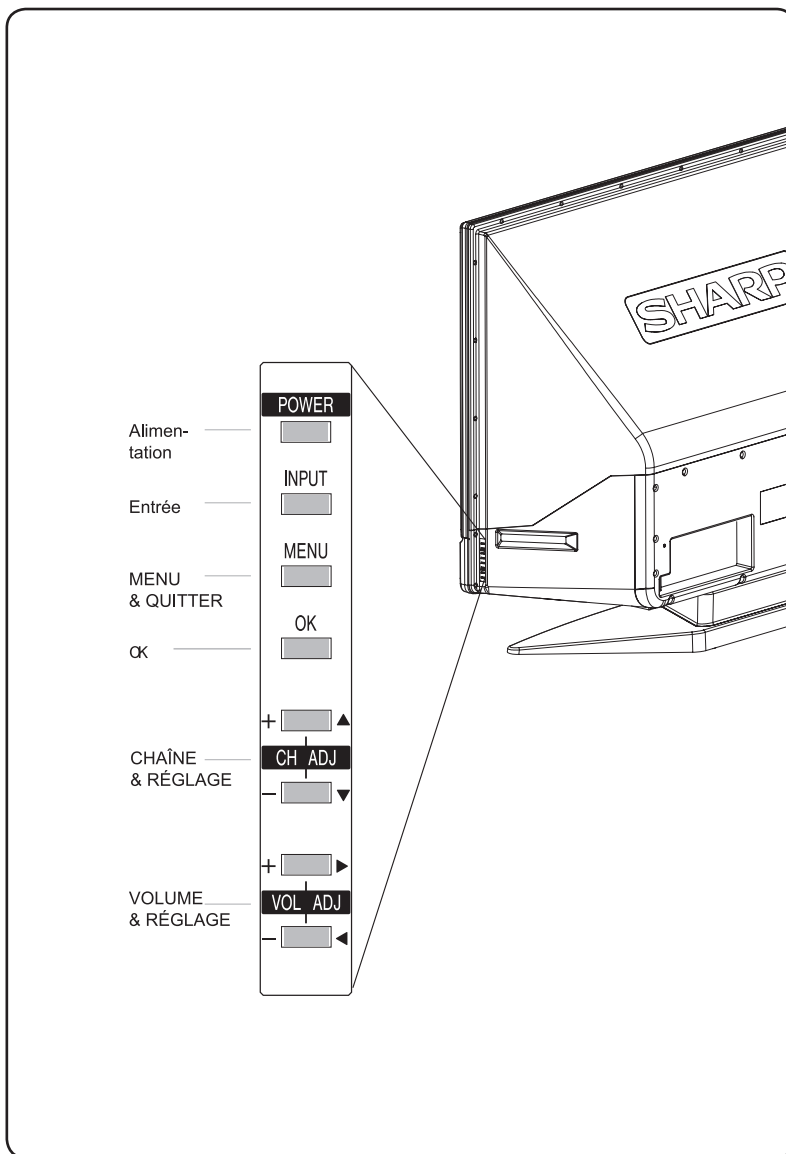

Voyant DEL d'état

Indicateur du panneau avant

DEL LAMPE

Indique l'état de la lampe de votre RPTV.

VOYANT DEL D'ALIMENTATION

S'allume en vert lorsque le produit est alimenté.

CAPTEUR DE LA TÉLÉCOMMANDE

Pointez la télécommande dans cette direction, car tous les signaux de la télécommande passent par cette fenêtre pour être transmis au capteur de la télécommande.

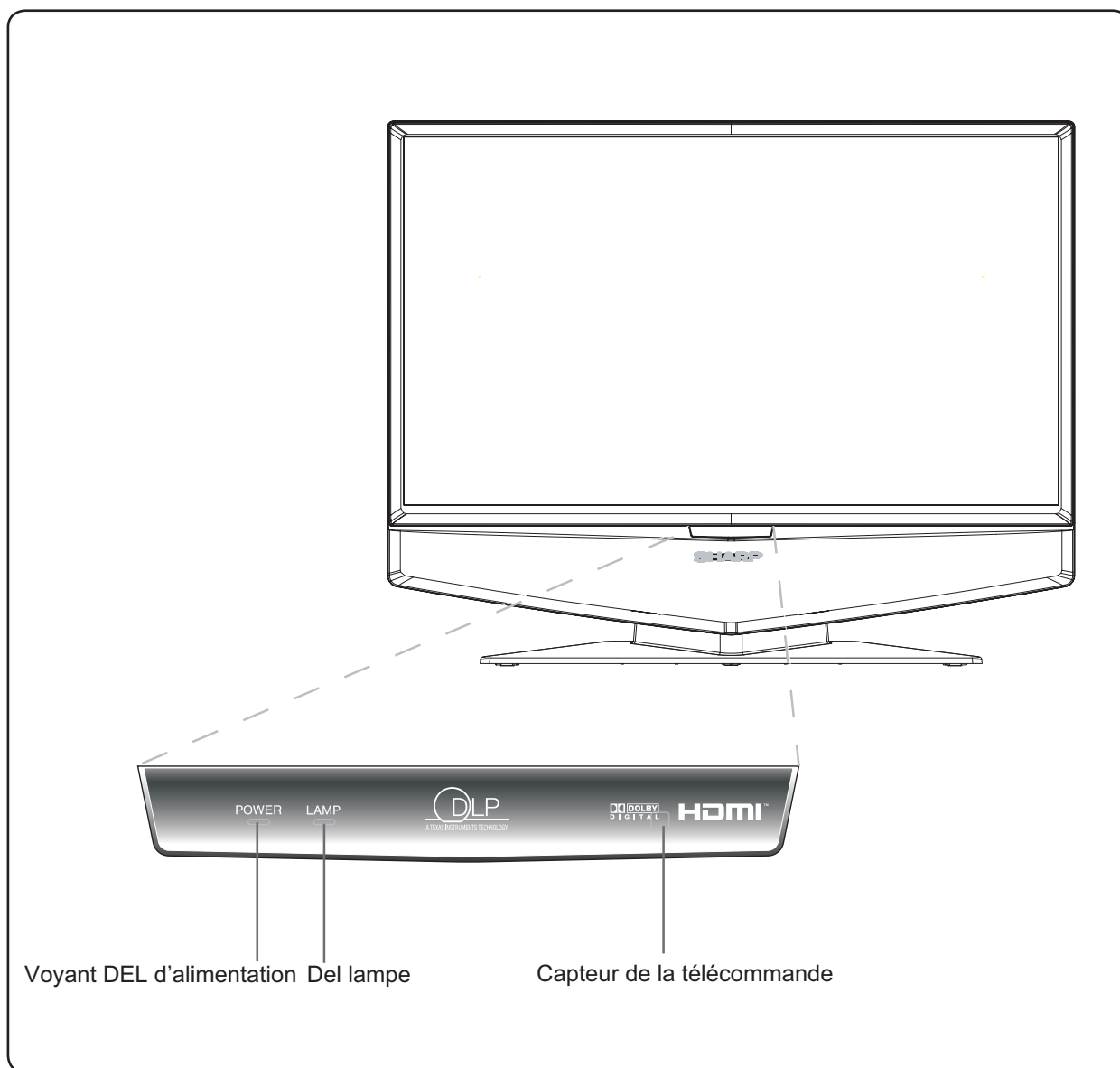

Fonctions des touches de la télécommande

La télécommande est un modèle complet capable de contrôler jusqu'à huit composants différents. Pour pouvoir être utilisée dans une pièce avec un éclairage minimal, la télécommande possède un rétroéclairage qui éclaire tous les boutons lorsque vous appuyez sur n'importe lequel des boutons. Le rétroéclairage s'arrête automatiquement quelques secondes après que vous avez appuyé sur le dernier bouton. Les fonctions des boutons de la télécommande sont expliquées ci-dessous.

Voyant DEL télécommande

Clignote lorsque la télécommande est en cours de programmation ou lors de l'envoi d'une commande à votre RPTV.

CONFIGURATION (SETUP)

Starts all programming sequences.

MARCHE/ARRÊT(POWER)

Permet "d'allumer" ou "d'éteindre" votre RPTV ou tout autre composant sélectionné.

Boutons composant

Vous pouvez programmer ces boutons pour sélectionner les composants sur lesquels vous voulez que la télécommande agisse.

Pavé numérique

TV	est préprogrammé pour contrôler votre RPTV.
DVD	permet de sélectionner un lecteur de DVD programmé.
VCR	permet de sélectionner un magnéto programme programmé.
CBL	permet de sélectionner un boîtier câble de dessus de poste.
SAT	permet de sélectionner un récepteur satellite programmé.
AMP	permet de sélectionner un récepteur programmé.
CD	permet de sélectionner un lecteur de CD programmé.
AUX	permet de sélectionner un composant programmé.

Utilisez ces boutons pour sélectionner directement une chaîne de télévision en tapant le numéro de la chaîne ou pour saisir le mot de passe.

Exemples:

Pour la chaîne 20, appuyez sur le bouton '2' puis sur le bouton '0' dans les cinq secondes.

FPour la chaîne 7 appuyez sur le bouton '7' et attendez environ cinq (5) secondes ; si vous ne voulez pas attendre, vous pouvez appuyer sur les boutons '0' et '7'

ENTRÉE (ENTER) de "." Sélection du canal auxiliaire

FLASHBACK : Retourner sur la chaîne précédente

SILENCE (MUTE) : Arrêt du volume

SOMMEIL(SLEEP) : Affiche l'état de mise en veille

ENTRÉE (INPUT) : Sélectionnez le type de signal DTV, AV1, AV2, AV3, COMP1, COMP2, RVB, HDMI, TV

VOL : Pour le contrôle du volume, appuyez sur le bouton "+" ou "-" CH : Pour sélectionner la chaîne, appuyez sur le bouton "+" ou "-"

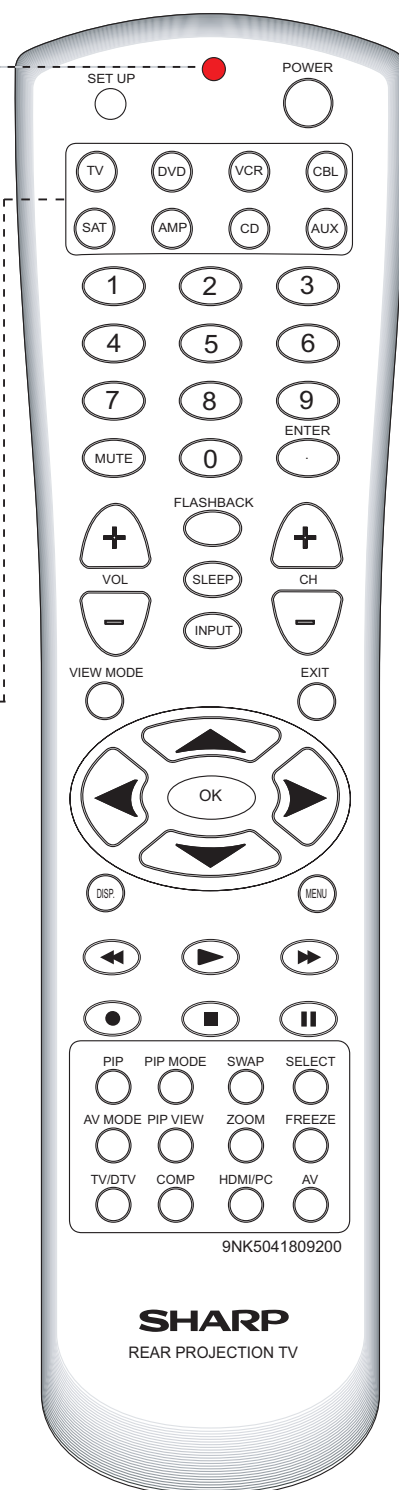

Fonctions des touches de la télécommande

MODE AFFICHAGE (VIEW MODE) AVEC VIDÉO

- ALLONGÉ 16:9
- BARRES LATÉRALES 4:3
- S.ALLONGÉ 16:10
- ZOOM

MODE AFFICHAGE (VIEW MODE) AVEC PC

- NORMAL
- ALLONGÉ 16:9
- POINT PAR POINT

QUITTER (EXIT)

Pour quitter l'OSD, le composant ou les menus.

▲, ▼, ◀, ▶

Utilisez ces boutons pour naviguer dans les menus OSD.

OK

Confirmer une action.

DISP

D'afficher l'état courant de la source vidéo, de l'audio (et le numéro de chaîne lorsque vous êtes en mode TV), sur l'écran de votre RPTV.

MENU

Permet d'activer le menu OSD ou de quitter l'OSD directement.

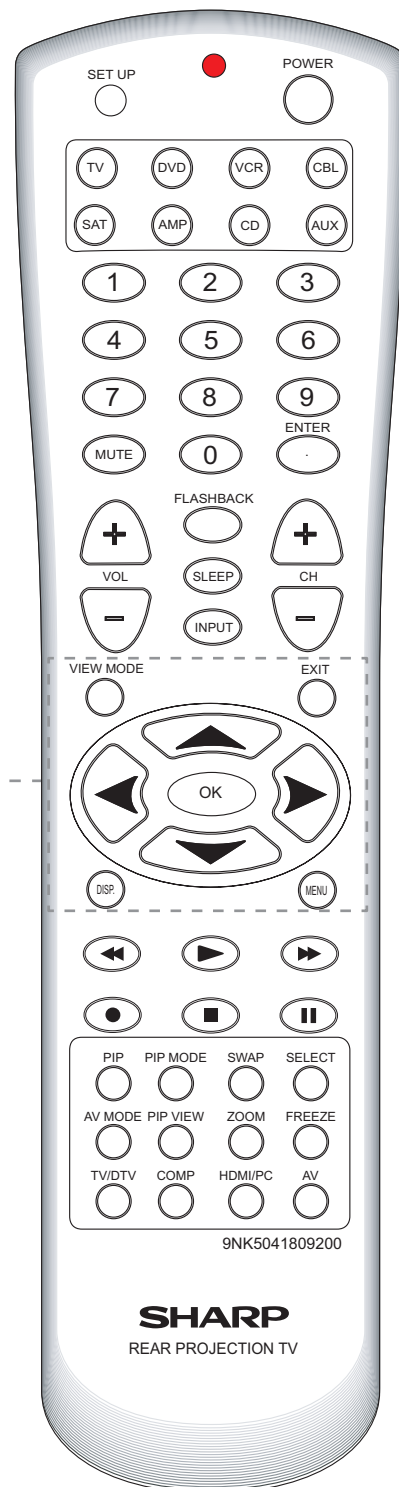

Fonctions des touches de la télécommande

PIP

Permet d'activer et de désactiver le mode PIP (Image incrustée) ou POP (Image sur image).

SELECT

Sélectionnez d'activer la fenêtre principale ou auxiliaire.

MODE PIP (PIP MODE)

Sélectionnez le type du mode PIP.

ÉCHANGE (SWAP)

Intervertissez l'image principal et la sous-image lorsque le mode PIP ou POP est activé. Changez de source vidéo pour l'image secondaire du PIP ou du POP. Lorsque vous choisissez l'un des boutons Composant, fait faire une pause au magnétoscope ou au lecteur de CD ou de DVD

ZOOM

Fait basculer le zoom pour agrandir l'affichage à 2X ou 4X.

ARRÊT SUR IMAGE (FREEZE)

Fait un arrêt sur image. Vous remarquerez que le continu vidéo et audio continue à changer, et lorsque vous appuyez de nouveau sur le bouton pour désactiver le mode Arrêt sur image, l'image ne retournera pas au point où elle a été arrêtée.

TV/DTV

Permet de sélectionner TV comme source vidéo.

COMP

Permet de sélectionner alternativement l'entrée composant COMP1 ou COMP2.

HDMI / PC

Permet de sélectionner alternativement l'entrée HDMI ou PC.

AV

Permet de sélectionner alternativement l'entrée AV1, AV2 ou AV3.

MODE AV (AV MODE)

Paramètres AV prédéfinis : STANDARD, FILM, JEU, TV PERSONNALISÉE, DYNAMIQUE (FIXE), DYNAMIQUE.

VUE PIP (PIP VIEW)

Faites basculer l'affichage de la fenêtre secondaire sur 16:9 ou 4:3



Memo



CUSTOMER SERVICE

For location of the nearest Sharp Authorized Service, or to obtain product literature, accessories, supplies, or customer assistance, please call 1-800-BE-SHARP.

LIMITED WARRANTY

CONSUMER LIMITED WARRANTY

SHARP ELECTRONICS CORPORATION warrants to the first consumer purchaser that this Sharp brand product (the "Product"), when shipped in its original container, will be free from defective workmanship and materials, and agrees that it will, at its option, either repair the defect or replace the defective Product or part thereof with a new or remanufactured equivalent at no charge to the purchaser for parts or labor for the period(s) set forth below.

This warranty does not apply to any appearance items of the Product nor to the additional excluded item(s) set forth below nor to any Product the exterior of which has been damaged or defaced, which has been subjected to improper voltage or other misuse, abnormal service or handling, or which has been altered or modified in design or construction.

In order to enforce the rights under this limited warranty, the purchaser should follow the steps set forth below and provide proof of purchase to the servicer.

The limited warranty described herein is in addition to whatever implied warranties may be granted to purchasers by law. ALL IMPLIED WARRANTIES INCLUDING THE WARRANTIES OF MERCHANTABILITY AND FITNESS FOR USE ARE LIMITED TO THE PERIOD(S) FROM THE DATE OF PURCHASE SET FORTH BELOW. Some states do not allow limitations on how long an implied warranty lasts, so the above limitation may not apply to you.

Neither the sales personnel of the seller nor any other person is authorized to make any warranties other than those described herein, or to extend the duration of any warranties beyond the time period described herein on behalf of Sharp.

The warranties described herein shall be the sole and exclusive warranties granted by Sharp and shall be the sole and exclusive remedy available to the purchaser. Correction of defects, in the manner and for the period of time described herein, shall constitute complete fulfillment of all liabilities and responsibilities of Sharp to the purchaser with respect to the Product, and shall constitute full satisfaction of all claims, whether based on contract, negligence, strict liability or otherwise. In no event shall Sharp be liable, or in any way responsible, for any damages or defects in the Product which were caused by repairs or attempted repairs performed by anyone other than an authorized servicer. Nor shall Sharp be liable or in any way responsible for any incidental or consequential economic or property damage. Some states do not allow the exclusion of incidental or consequential damages, so the above exclusion may not apply to you.

THIS WARRANTY GIVES YOU SPECIFIC LEGAL RIGHTS. YOU MAY ALSO HAVE OTHER RIGHTS WHICH VARY FROM STATE TO STATE.

Model Specific Section

Product model number and description:

**56DR650-56" DLP High Definition Rear Projection Television
65DR650-65" DLP High Definition Rear Projection Television**

Warranty period for the above models:

One (1) year parts and labor from the date of purchase including the original lamp*. During this period Sharp will, at Sharps option exchange the defective lamp with a new or refurbished unit at no cost to the customer. Labor charges to replace the lamp are not covered under warranty. The lamp is considered a user replaceable part.

*If this product is used for Commercial, Institutional or Industrial applications the original lamp warranty period is 90 days from the original date of purchase.

Item(s) excluded from Warranty coverage (if any):

Non-rechargeable batteries

Where to Obtain Service:

From an authorized Sharp Service center located in the United States. To find a location near you please call Sharp toll free at 1-800-BE-SHARP

How to Obtain Service:

If, after following the operation manuals instructions and checking the Troubleshooting section, you feel that service is necessary.

Contact the nearest authorized Sharp service center to obtain-in home service for this product. The Service provider will come to your home and if necessary remove the product and upon completion reinstall it. Please be sure to have **Proof of Purchase** available before calling.

To obtain product information please call 1-800-BE-SHARP or visit us online at www.sharppusa.com

SHARP®

SHARP ELECTRONICS CORPORATION

Sharp Plaza, Mahwah, New Jersey 07430-2135

SHARP CORPORATION

Printed in Mexico
9NK5010017401